

www.koltepatil.com



DISCOVER THE FUTURE OF CONTEMPORARY



On Hosur Road, Electronic City



Kolte Patil has been creating landmarks for 25 years.

Founded over 2 decades ago and guided by a simple yet profound philosophy; 'Creation, not construction', Kolte Patil Developers Ltd. is one of the foremost real estate companies, headquartered in Pune. Listed on NSE and BSE, Kolte Patil is Pune's largest developer and has completed 20 million sq. ft. of landmark developments in Pune and Bengaluru. It is also present in Mumbai with some upscale redevelopment projects.

Headed by a team of visionaries and dynamic leaders, Kolte Patil has till date built projects in multiple segments such as residential, commercial, retail, IT parks, and with focus on delivering the futuristic and self-sustained integrated townships. The long standing mission of the company is to dedicate itself to create spaces that blend in with the surroundings and exude vitality and aesthetic appeal, making the spaces present-perfect and future-proof. The core values of the company—honesty, innovation, excellence, eco-friendliness, technology, sustainability, value and commitment to time schedules are perfectly aligned with the living and working spaces it builds.

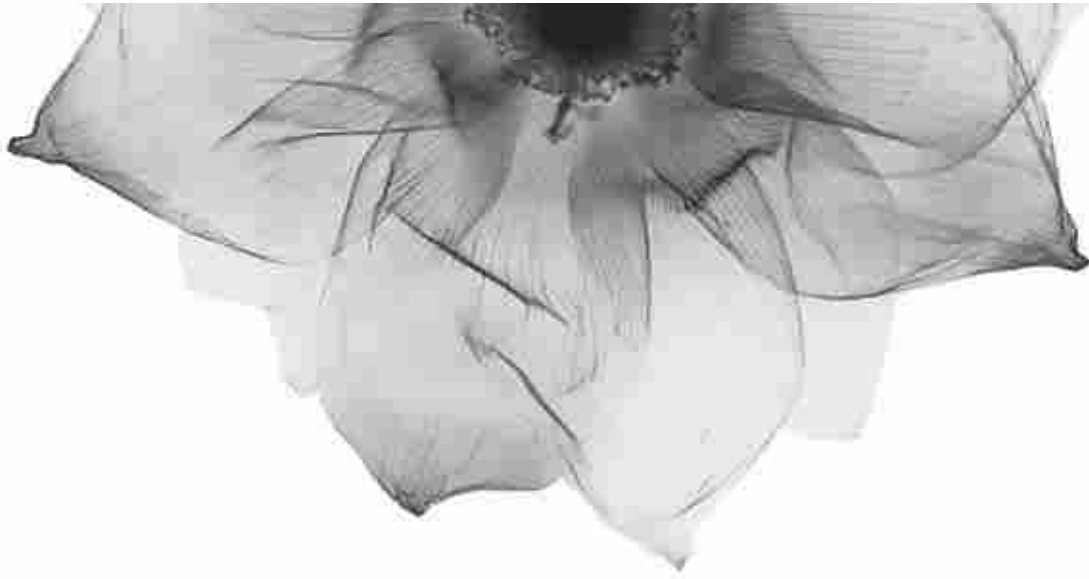

I TOWERS

Introducing I TOWERS,
a new era residential brand from
Kolte Patil Developers.

Born from a legacy of 25 years of excellence, comes a world inspired by you. A world beyond luxury — designed with you at center of it all.

Built with innovations that make life almost perfect, I TOWERS redefines modern living. Perfectly located at the hub of tomorrow. Integrating technology, design, aesthetics, and a world of sustainable thinking, I TOWERS starts and ends with your family and you.

From connectivity to convenience, and space optimisation to energy efficiency, I TOWERS Exente is meticulously planned, redefining the future of contemporary living.



Welcome home to excellence,
exuberance and exclusivity.



Image shown is an artistic impression only. Please read the complete disclaimer provided at the end of this brochure.

EXPERIENCE THE EXCELLENCE OF

IMAGINATION

IN DESIGN, AESTHETIC

AND EXECUTION.

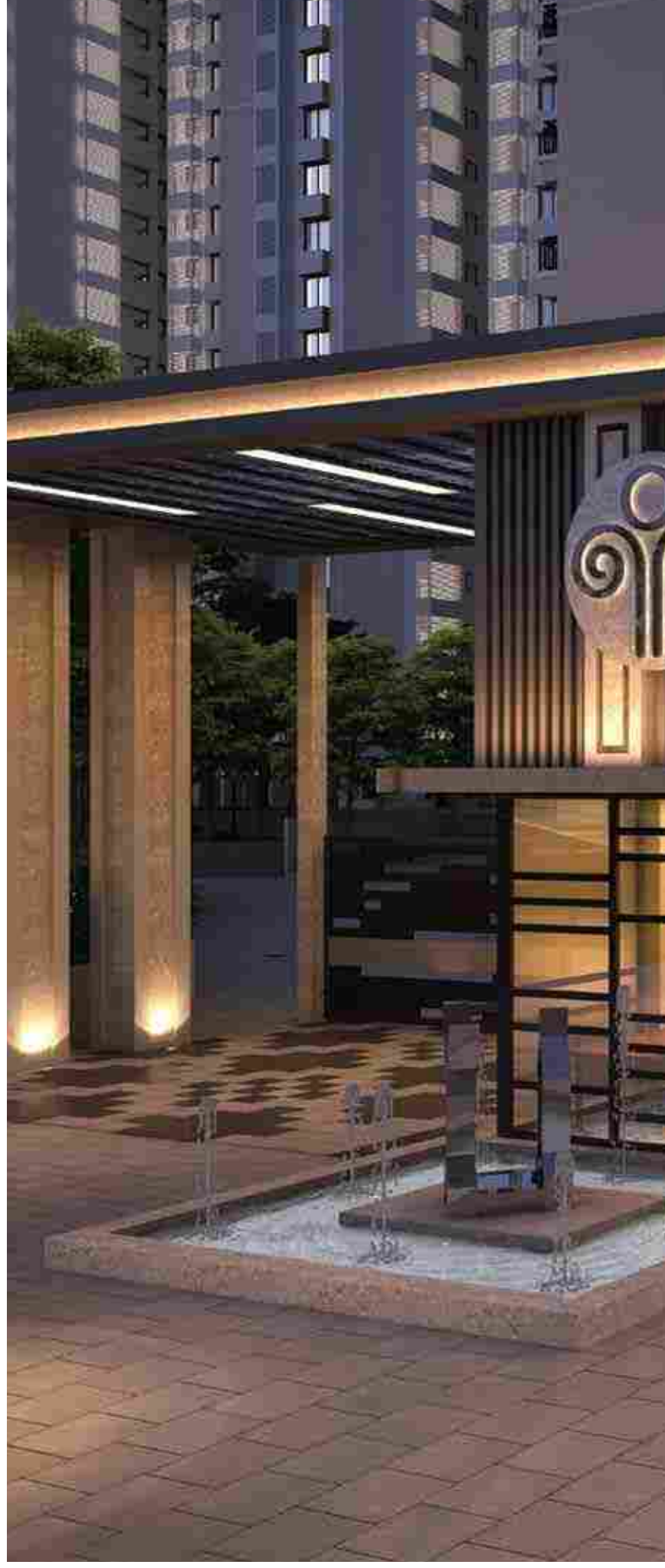



Image shown is an artistic impression only. Please read the complete disclaimer provided at the end of this brochure.



GARDENS

GALORE



Image shown is an artistic impression only. Please read the complete disclaimer provided at the end of this brochure.

At ITOWERS Exente, with a variety of natural spaces, designed for almost every occasion we bring the garden back to the Garden City.

Take an Aromatic Garden Walk. Pick herbs in the Spice & Herb Garden. Better still, calm your senses in the Contemplation Garden, all while the children conjure adventures in the awesome little Secret Garden.

A photograph of a dense forest with vibrant green foliage. The trees are out of focus, creating a soft, bokeh effect. Overlaid on the lower half of the image is the text "BECAUSE EVERYONE LOVES A BREATH OF FRESHNESS..." in a white, thin-lined, sans-serif font. The text is arranged in five lines, centered horizontally. The background image is framed by a thin white border.

BECAUSE
EVERYONE
LOVES A
BREATH OF
FRESHNESS...

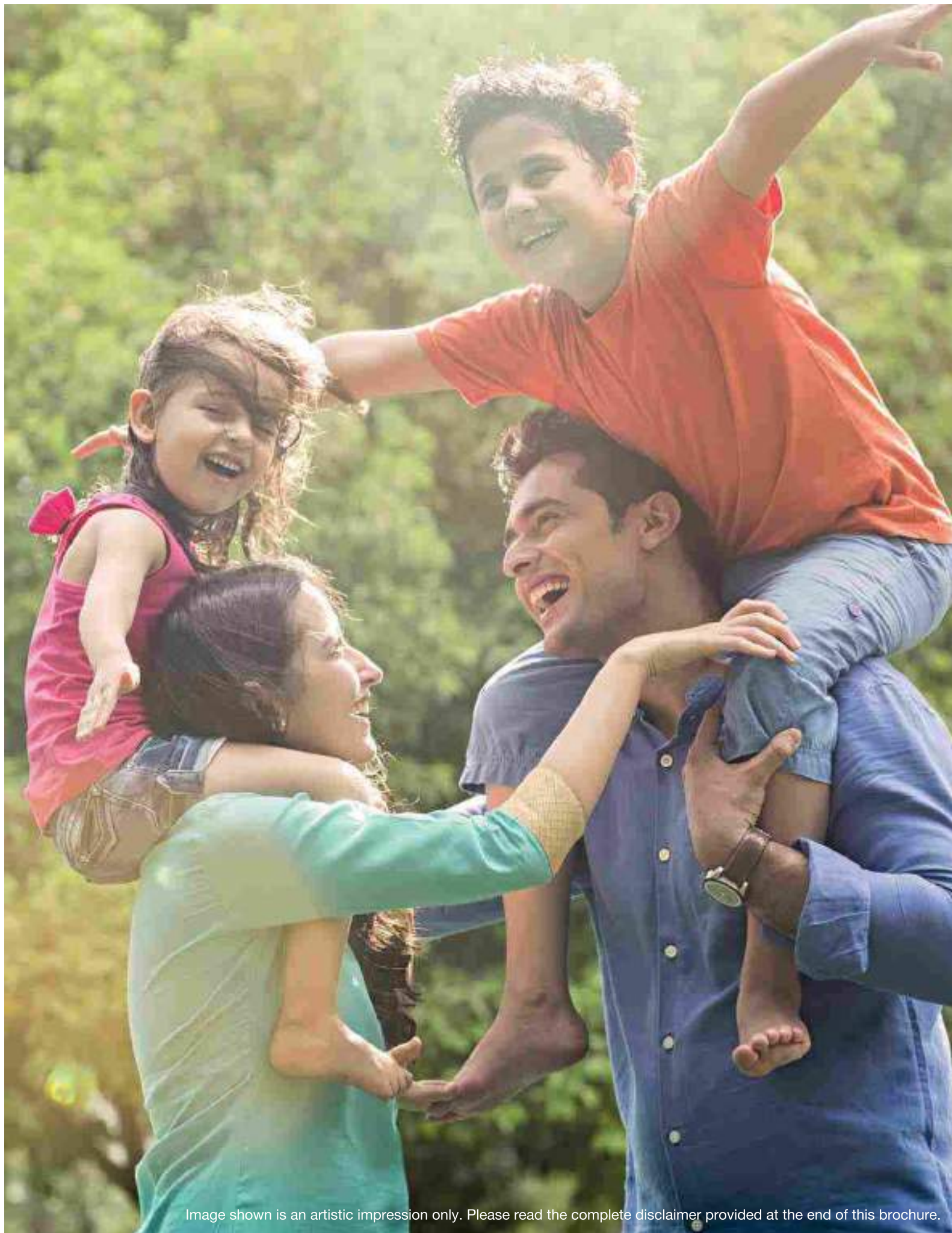

Image shown is an artistic impression only. Please read the complete disclaimer provided at the end of this brochure.

BEHOLD THE EXUBERANCE OF
INSPIRATION

WITH HOMES THAT REDEFINE
CONTEMPORARY LIVING.



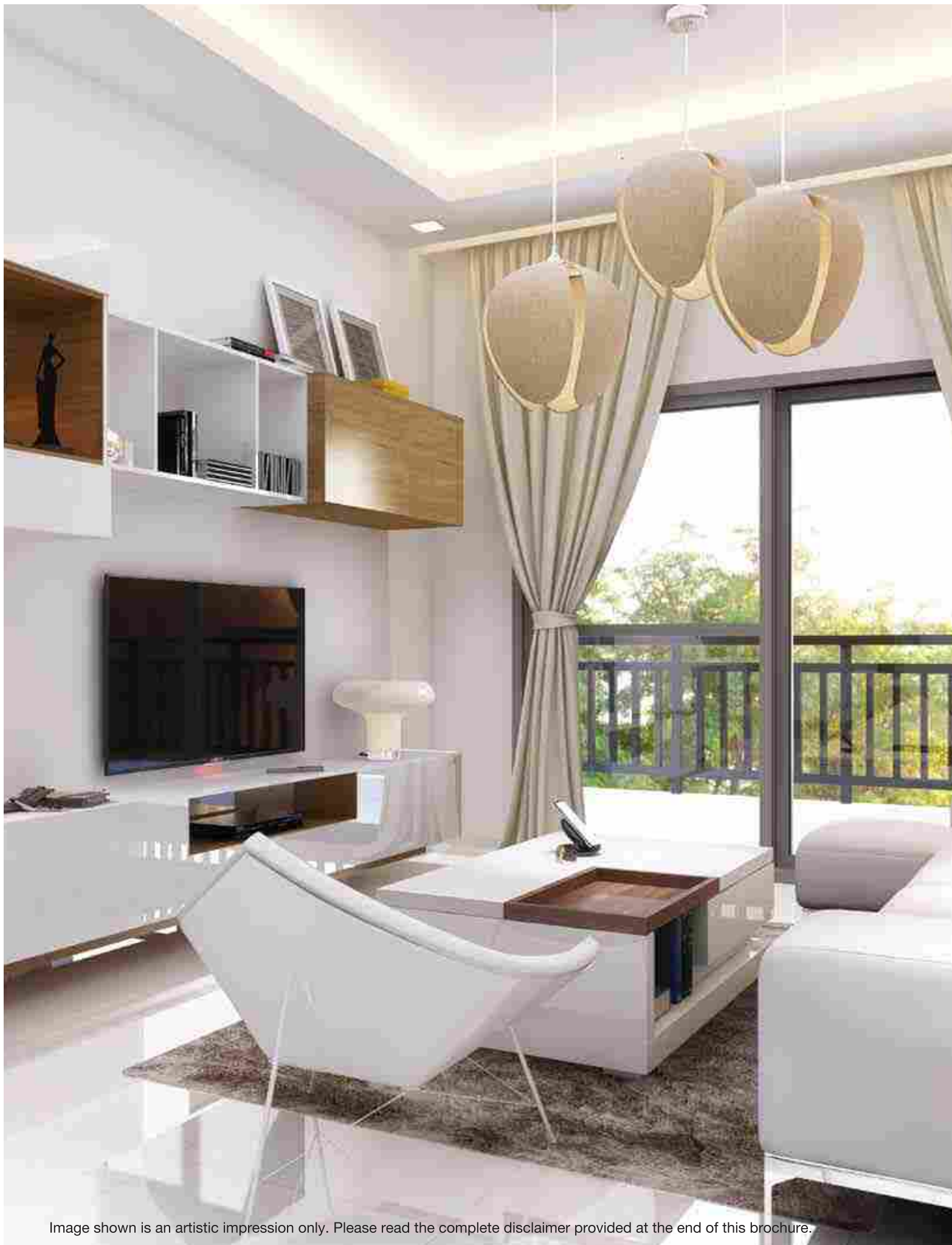
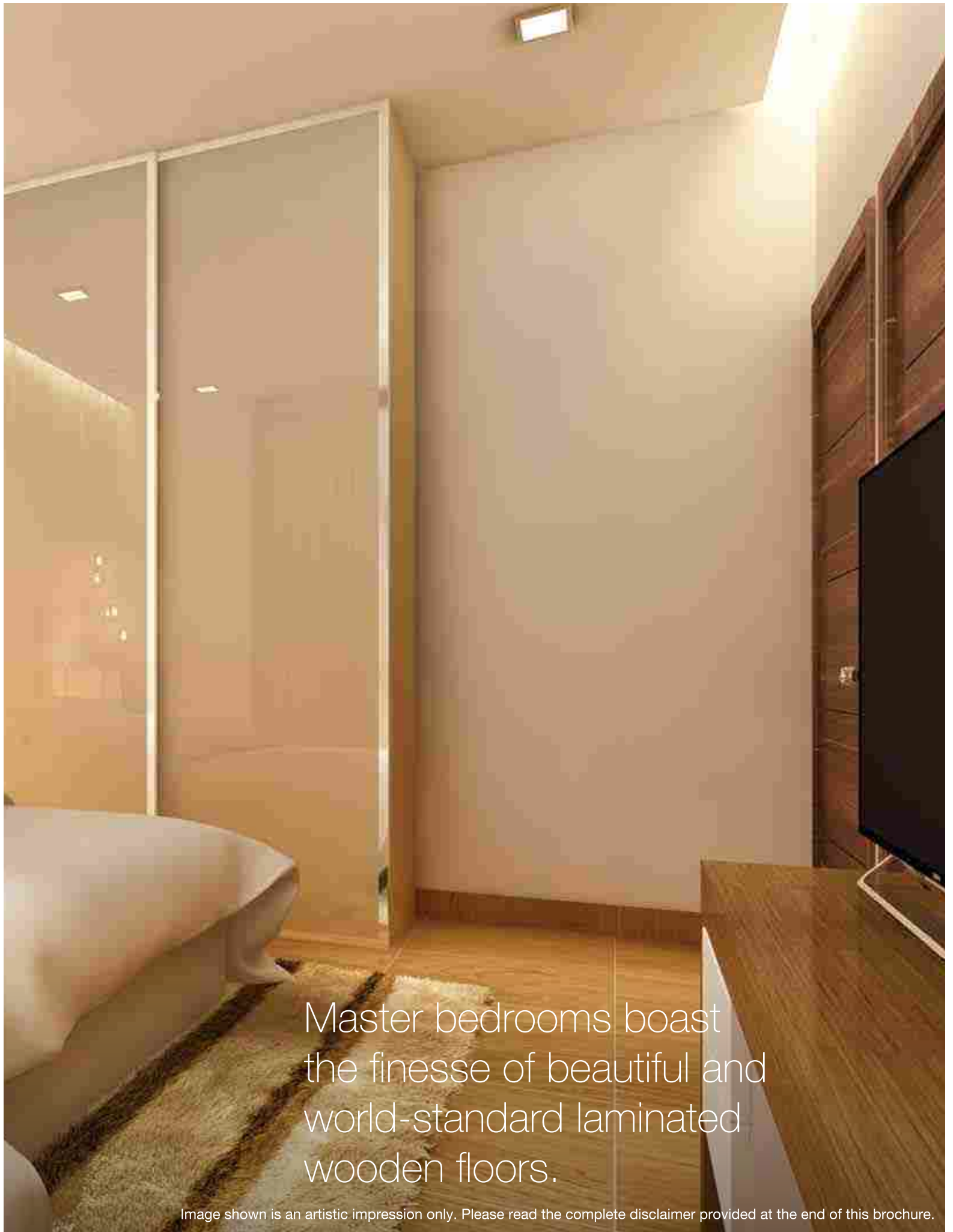

Image shown is an artistic impression only. Please read the complete disclaimer provided at the end of this brochure.

STEP UP TO THE ELEGANCE OF WOOD,





Master bedrooms boast the finesse of beautiful and world-standard laminated wooden floors.

Image shown is an artistic impression only. Please read the complete disclaimer provided at the end of this brochure.

MAKE ROOM FOR IMAGINATION.



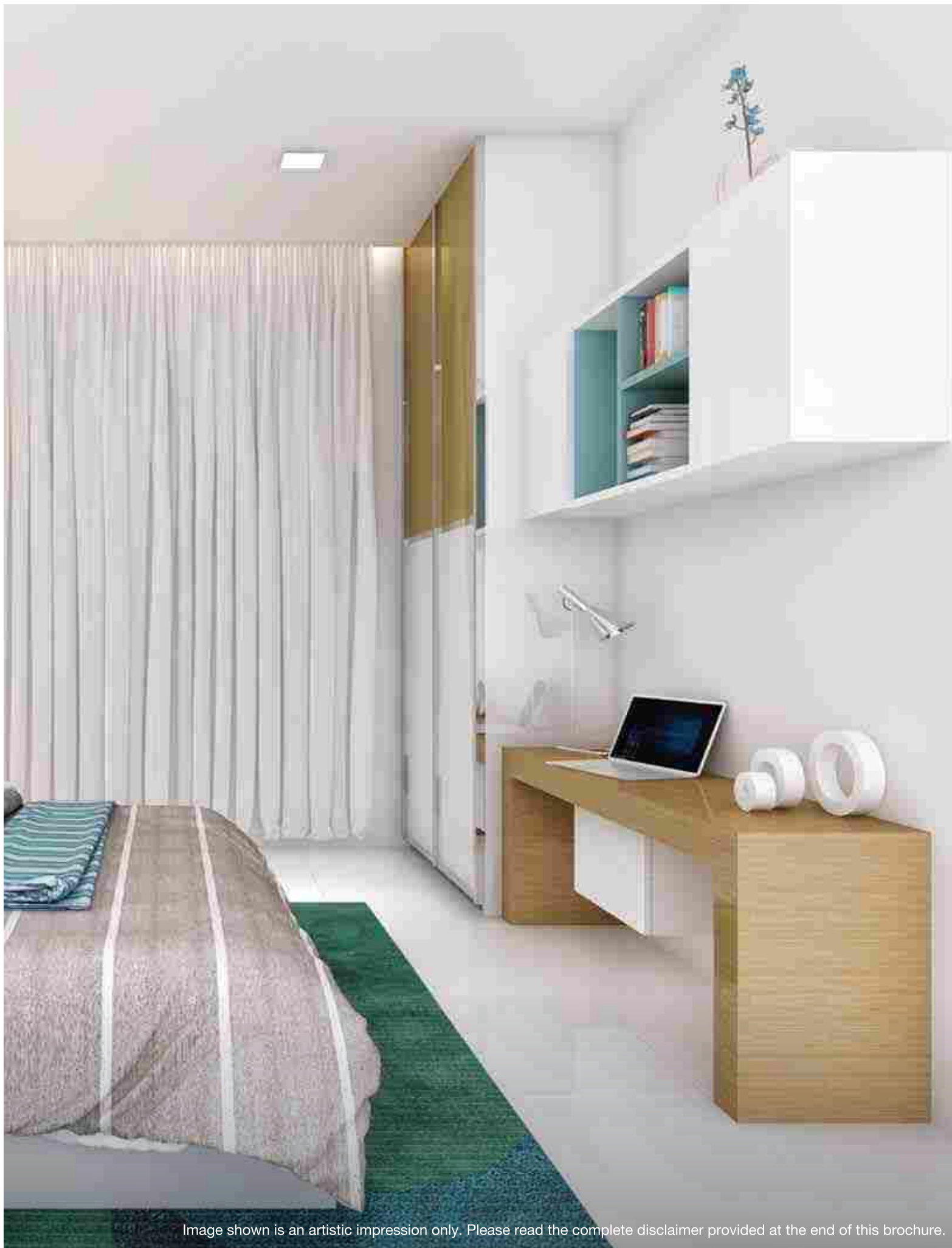

Image shown is an artistic impression only. Please read the complete disclaimer provided at the end of this brochure.

A hand is shown on the right side of the frame, holding a small, light-colored rectangular object, possibly a card or a piece of paper, near a window. Sunlight is streaming in from the window, creating a warm, golden glow. The background is a blurred view of a landscape with trees and a building. The overall scene is bright and airy, suggesting a sunny day.

BRING HOME THE SUNSHINE

with optimum daylighting parameters.

Image shown is an artistic impression only. Please read the complete disclaimer provided at the end of this brochure.



ENJOY THE EXCLUSIVITY OF
INNOVATION
WHERE NEXT-GENERATION AMENITIES
DEFINE A BRIGHTER FUTURE.



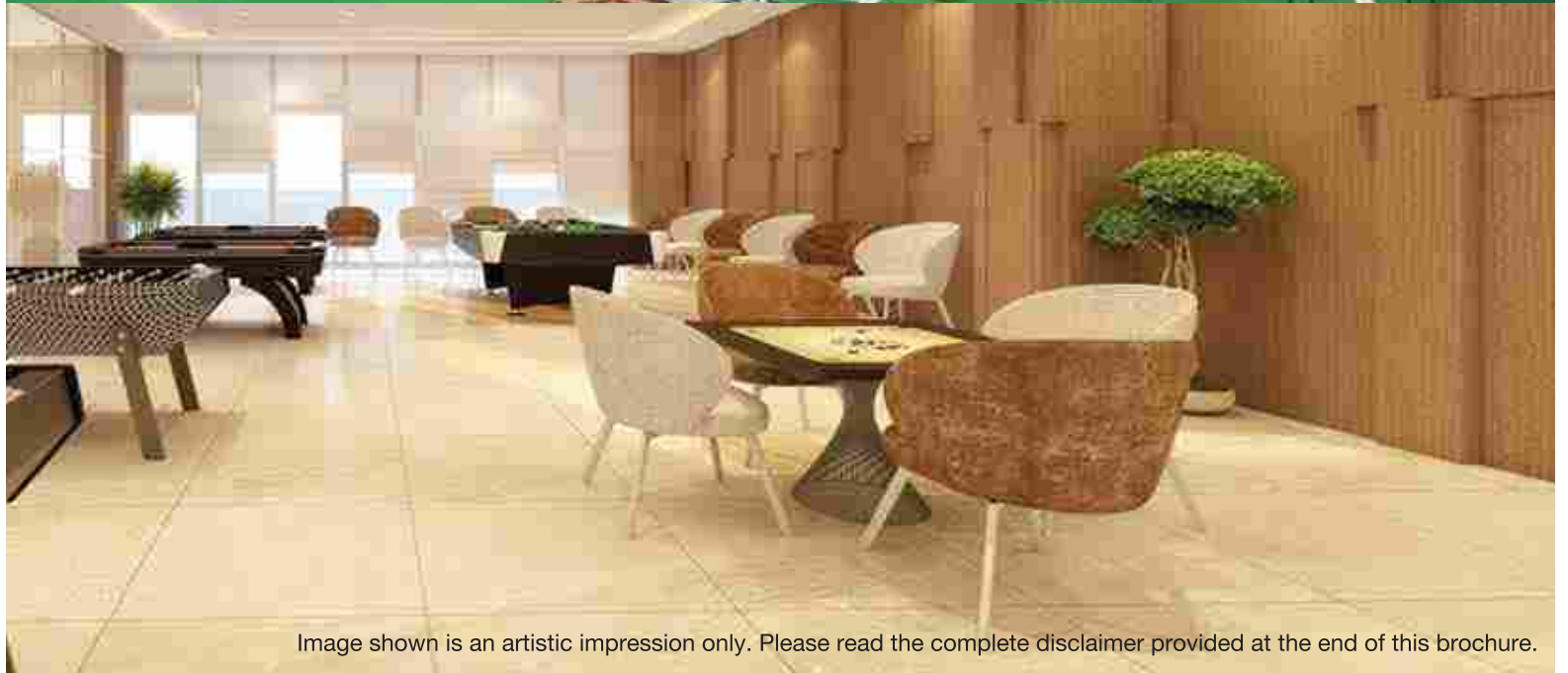

Image shown is an artistic impression only. Please read the complete disclaimer provided at the end of this brochure.



EXPLORE

TOMORROW

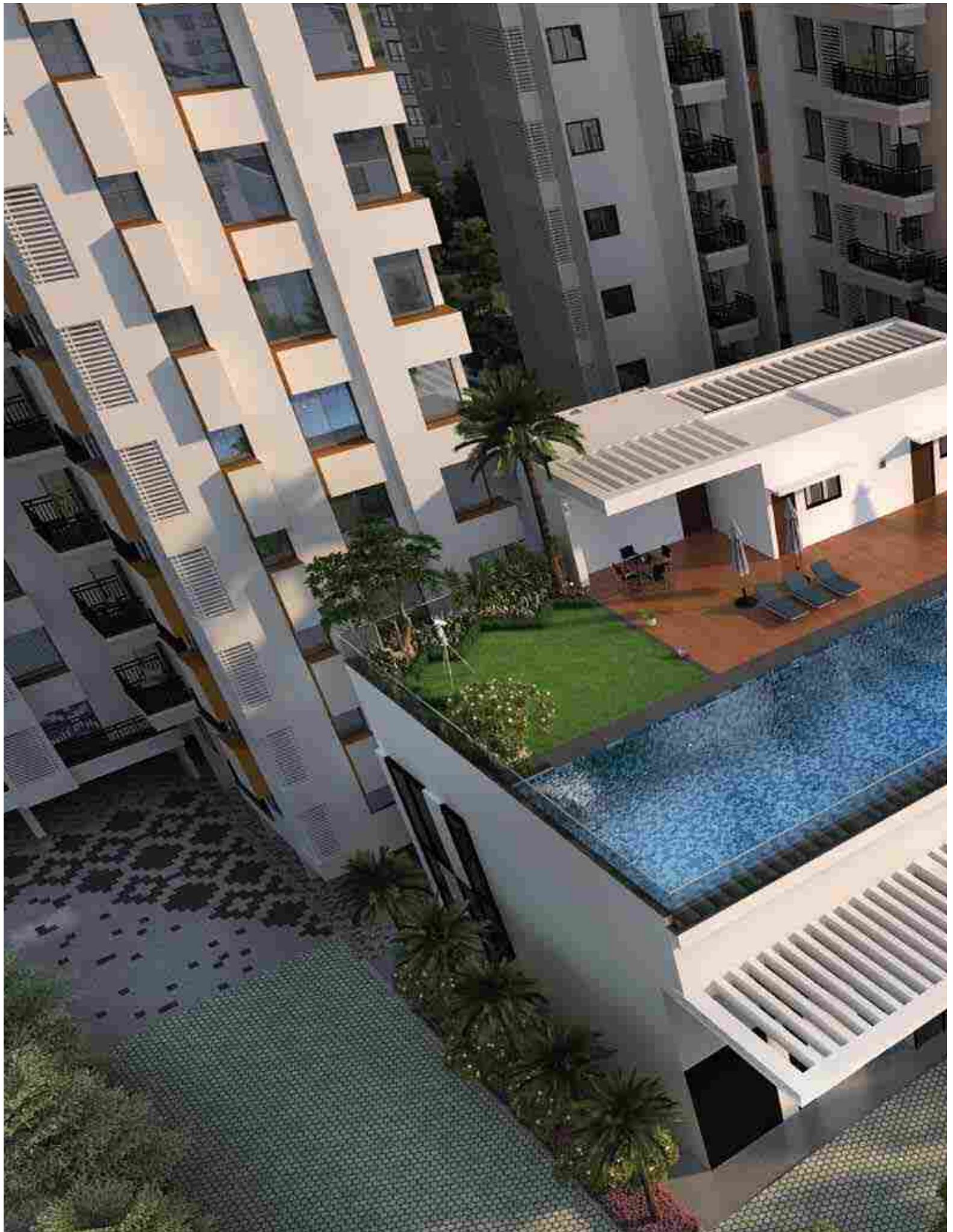

Image shown is an artistic impression only. Please read the complete disclaimer provided at the end of this brochure.

At I TOWERS Exente, we have envisioned
a universe of learning and information.

The Digital Library — a cutting edge interactive experience designed for the whole family
is just one of the many thoughtful innovations you come home to.



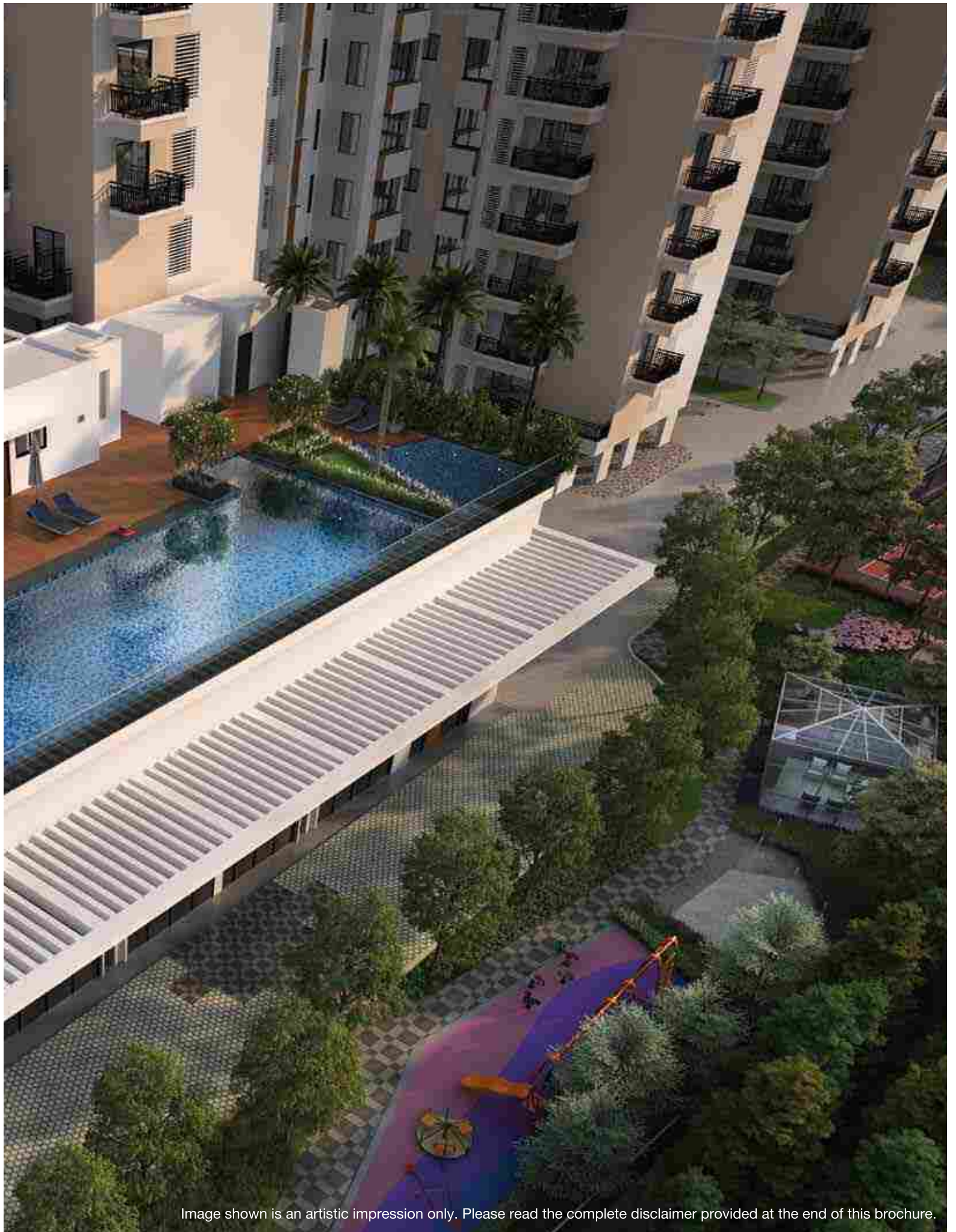

Image shown is an artistic impression only. Please read the complete disclaimer provided at the end of this brochure.

OUTDOOR



Image shown is an artistic impression only. Please read the complete disclaimer provided at the end of this brochure.



Children's
Playground



Multipurpose
Court



Barbeque
Pavilion



Jogging Track



Outdoor
Fitness Station



Cricket Pitch



Volleyball Court



Kids Pool



Wi-Fi Enabled
Campus



Alfresco
Courtyard



Aromatic
Garden Walk



Interactive
Water Jets



Main Pool

THE
THINGS
YOU CAN
DO

INDOOR



Party Hall



Indoor Games



Work from Home Cubicles



Gymnasium



Golf Simulator



Lounge



Crèche



Cards Room



Convenience Store



Aristotle Digital Library



Squash Court

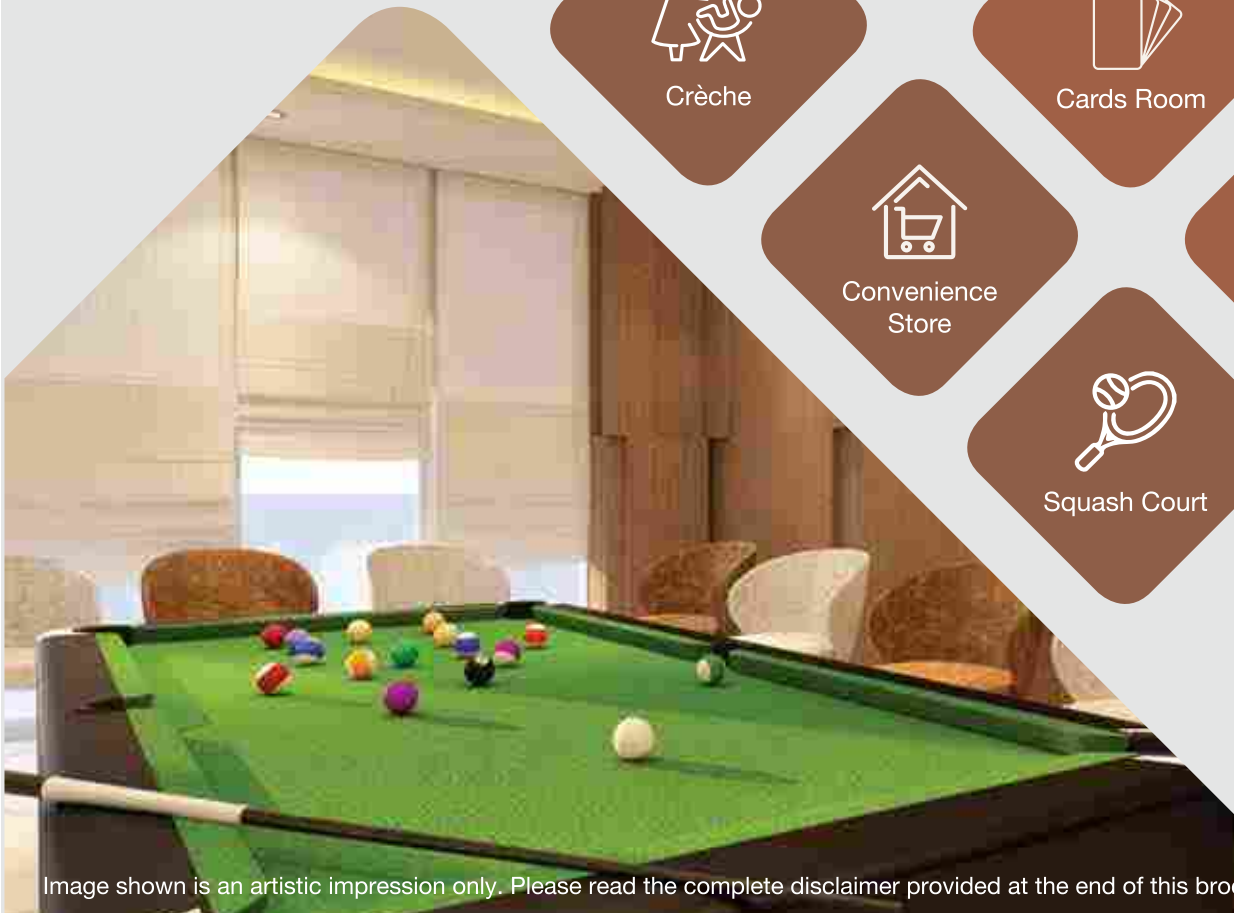
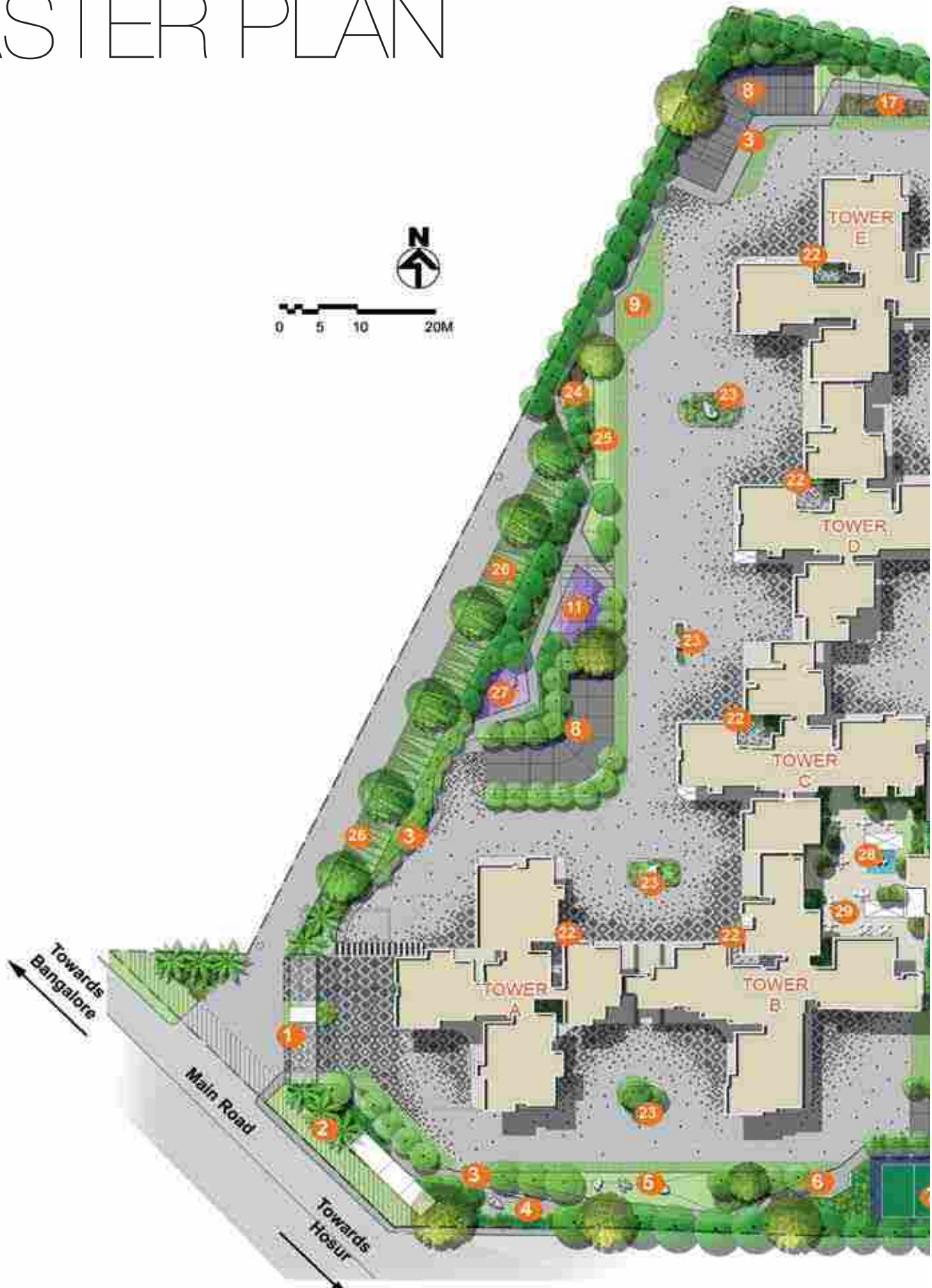

Image shown is an artistic impression only. Please read the complete disclaimer provided at the end of this brochure.



STAY
FIT
STAY
INSPIRED

MASTER PLAN





- 1 ENTRY PORTAL
- 2 SIGNAGE WALL
- 3 JOGGING TRACK
- 4 DRY GARDEN
- 5 SCULPTURE GARDEN
- 6 RESTING AREA
- 7 VOLLEYBALL COURT
- 8 VEHICLE RAMP TO & FROM BASEMENT
- 9 GRASS CELL PAVING
- 10 BERM WITH SEATING
- 11 CHILDREN'S PLAYGROUND
- 12 INTERACTIVE WATER JETS
- 13 SOLARIUM
- 14 SEASONAL TREE GARDEN
- 15 PARTY LAWN
- 16 BARBECUE PAVILION
- 17 AROMATIC GARDEN WALK
- 18 MULTI PURPOSE COURT (FUTSAL AND BASKETBALL COURT)
- 19 TENNIS COURT
- 20 CONTEMPLATION GARDEN
- 21 SECRET GARDEN
- 22 DROP-OFF AREA / TOWER ENTRY LOBBY
- 23 FEATURE ROUND-ABOUT ISLAND
- 24 SPICE & HERB GARDEN w/ RESTING PERGOLA
- 25 CRICKET PITCH
- 26 VISITOR'S PARKING
- 27 OUTDOOR FITNESS STATION
- 28 WATER FEATURE W/ FOCAL SCULPTURE
- 29 ALFRESCO
- 30 MAIN POOL
- 31 KIDS POOL

INVEST IN THE PERFECT WORK-LIFE INTEGRATION.



Directly

connected

to NH7 two-way access from
service road



Quick

access

to Electronic City phase 1
and 2

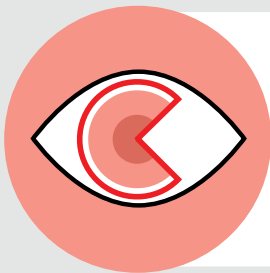

3

side open

view of the city

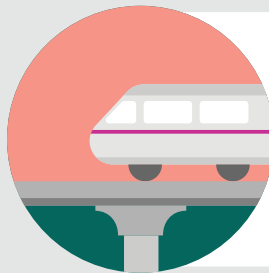

300

meters

from proposed metro station



10

min walk

to Infosys, GE, TCS,
Tech Mahindra, Schneider
Electric, HP



20

mins drive

to Hosur Industrial area



Image shown is an artistic impression only. Please read the complete disclaimer provided at the end of this brochure.

SPECIFICATIONS

EVERYTHING YOU NEED TO KNOW

FLOORING

Foyer, Living & Dining

Premium Vitrified Tiles

Kitchen

Premium Vitrified Tiles

Master Bedroom

Laminated Wooden Flooring

Master Bedroom Toilet

Anti-Skid Ceramic Tiles

Other Bedrooms

Premium Vitrified Tiles

Other Toilet

Anti-Skid Ceramic Tiles

Balcony

Anti-Skid Ceramic Tiles

Utility

Anti-Skid Ceramic Tiles

Lobby Area

Premium Vitrified Tiles

KITCHEN

Granite Slab with SS Sink & Drain Board mounted with Sink Mixer & Piped Gas Provision

2 Feet Wall Dado of Premium Ceramic Glazed Tiles

TOILETS

Master Bedroom Toilet

Fully Loaded Items – Granite Top with Wash Basin, Wall Mounted WC with Health Faucet, Rain Shower, Geyser 25 ltr capacity, Mirror, Towel Rail & Soap Stand

CP Fittings

Jaguar or Equivalent

Other Toilet

Wall Mounted WC with Health Faucet, Regular Wash Basin

ELECTRICAL

Supply

4 BHK: 5 KW

3 BHK: 5 KW

2.5 BHK: 3 KW

2 BHK: 3 KW

1 BHK: 2 KW

Back Up

4BHK: 1.5 KW

3 BHK: 1 KW

2.5 BHK: 1 KW

2 BHK: 0.5 KW

1 BHK: 0.5 KW

Wiring

Anchor or Equivalent

Switch Plates

Schneider or Equivalent

PAINT

External

Exterior Emulsion

Internal

Walls: Emulsion

Ceiling: OBD

Doors: Enamel Paint for Internal

Doors and MS Items

Windows

UPVC Windows with Mosquito

Mesh

Balcony Railing

MS Railing

DOORS

Main Door

Teak Wood Door Frame

Veneered Flush Door Shutter

Internal Door

Sal Wood Door Frame

Masonite Skin Shutter Doors

Toilet Door

Sal Wood Door Frame

Masonite Skin Shutter Doors

Door Hardware

Preimum Quality

AC PROVISION

Living Room

Master Bedroom

TV POINTS

Living Room

All Bedrooms

GROUND FLOOR ENTRANCE

LOBBY & LIFT LOBBY

Granite Flooring & Cladding

Typical Floor Lobby

Premium Vitrified Tiles for floor &

Granite Border for the lift wall.

Common Staircase

Kota Stone

Others

DTH Infrastructure

EPABX

Garbage Chute

Solar Lighting in Outdoor Areas



Koramangala 15 Mins	HSR Layout 25 Mins	MG Road 40 Mins	JP Nagar 25 Mins	Jaya Nagar 25 Mins	Indira Nagar 40 Mins
------------------------	-----------------------	--------------------	---------------------	-----------------------	-------------------------

STAY CONNECTED
TO THE FUTURE.

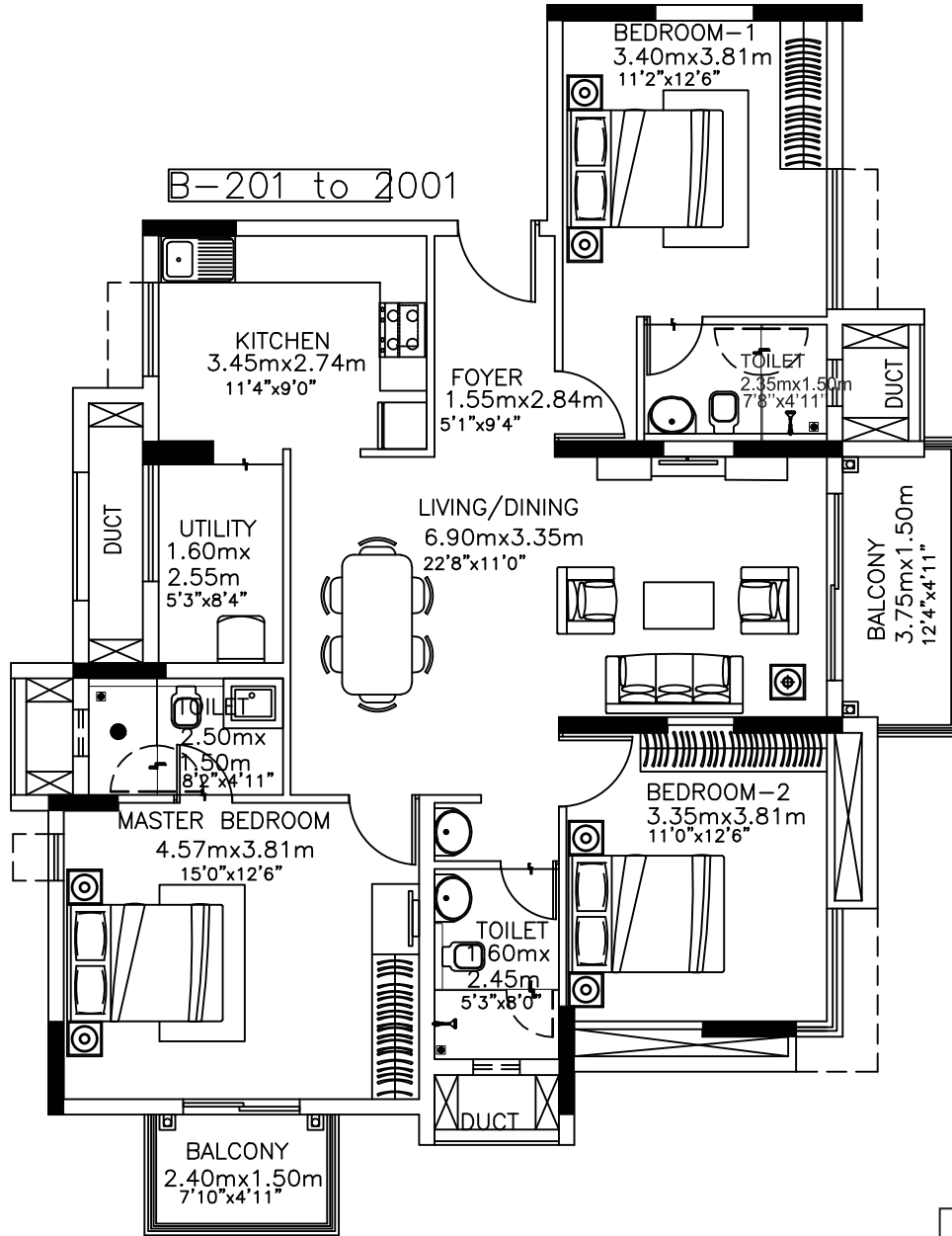

B 201 TO 2001 : 3 BED FLAT

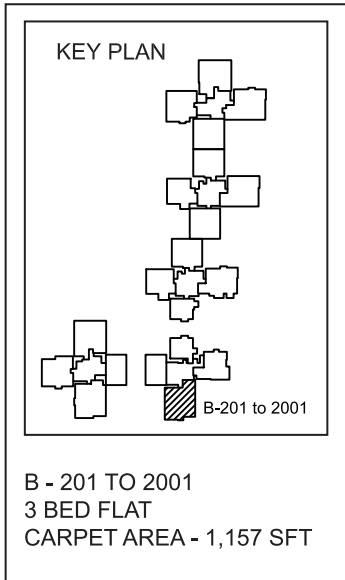

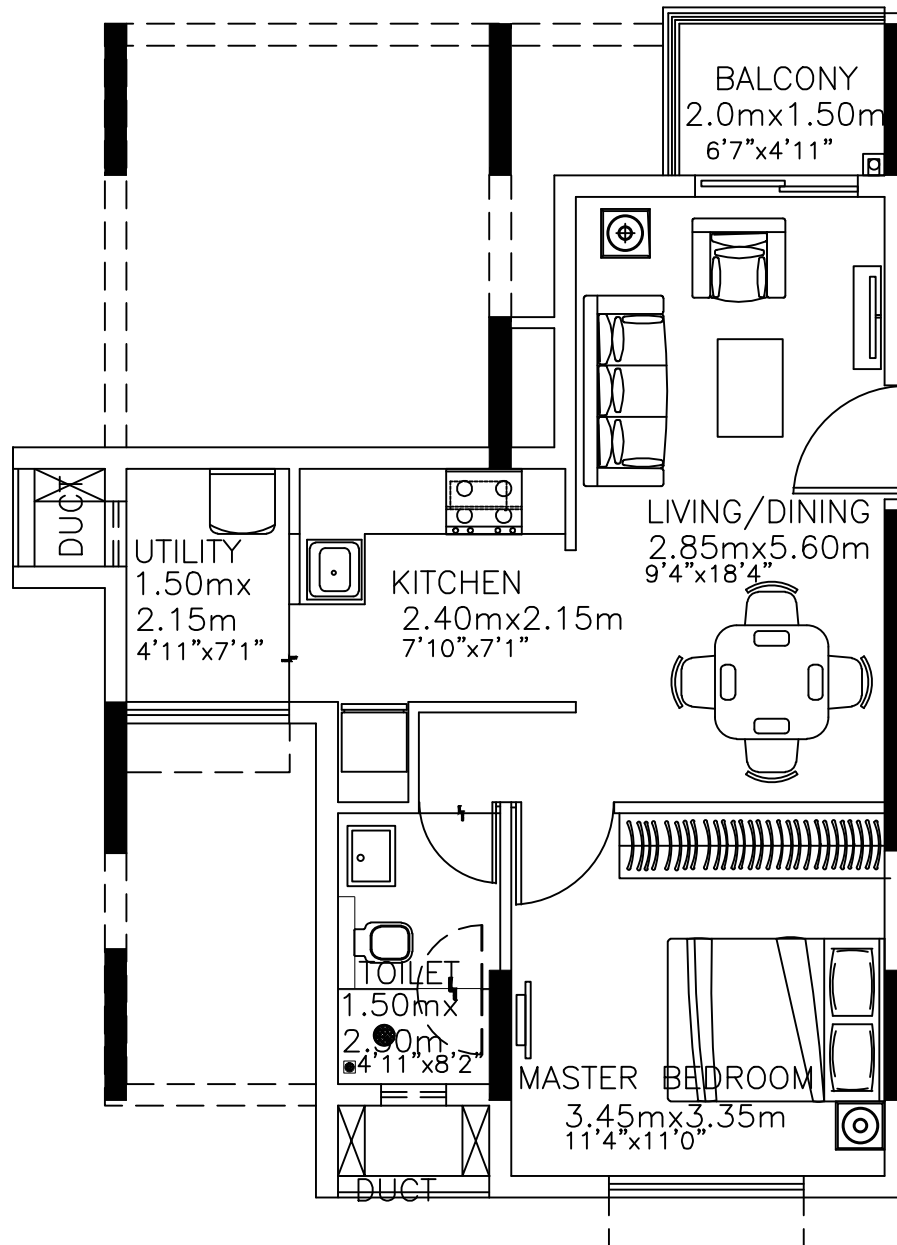

B 202 TO 1002 : 1 BED FLAT

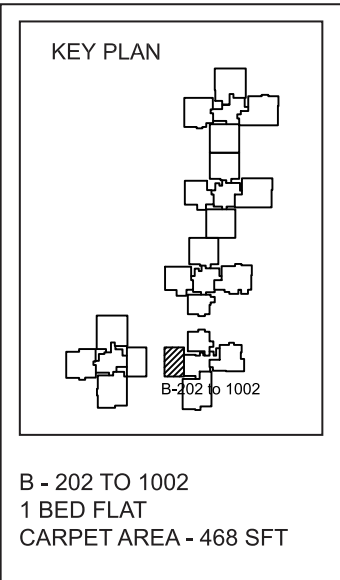

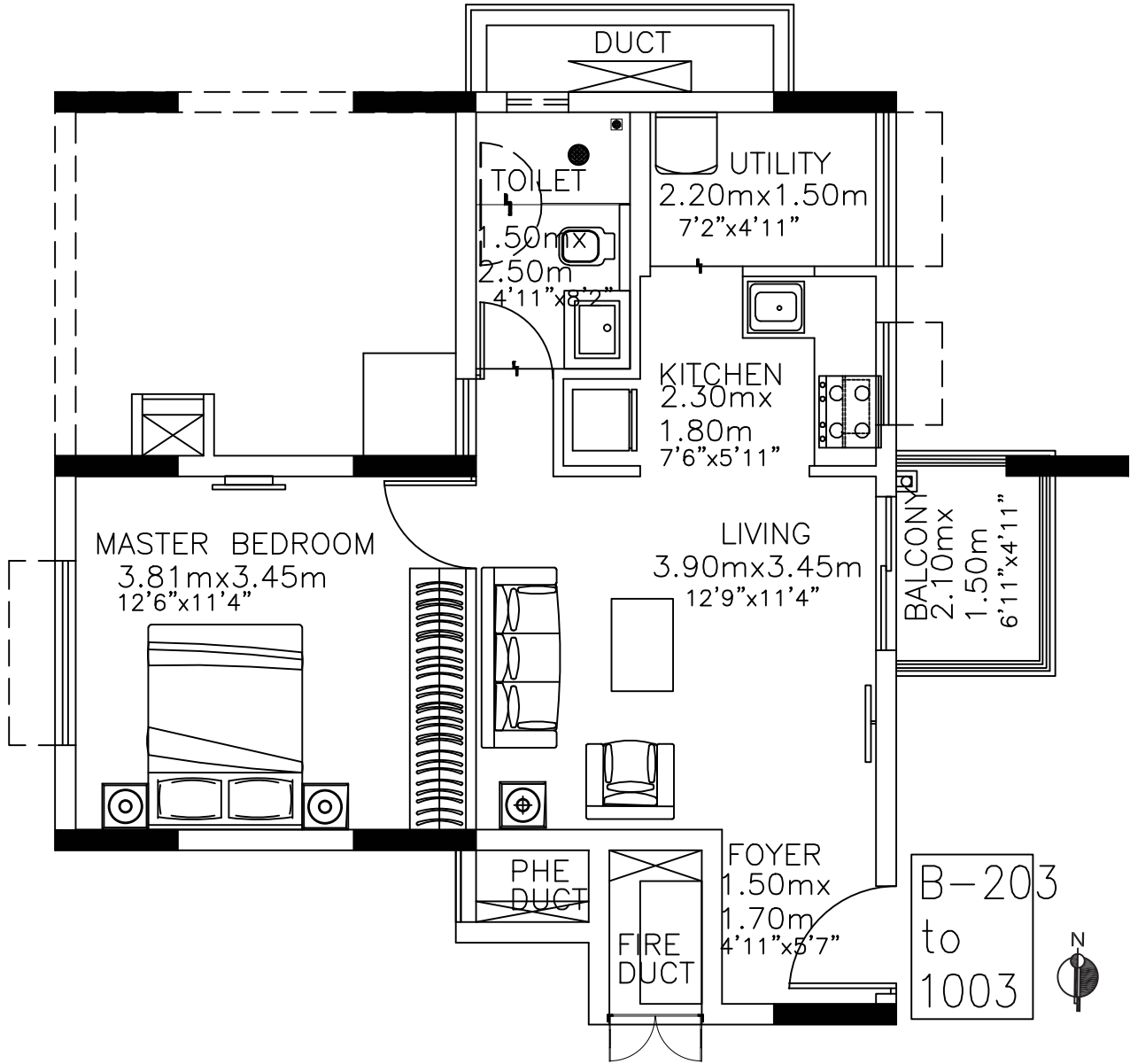

B 203 TO 1003 : 1 BED FLAT

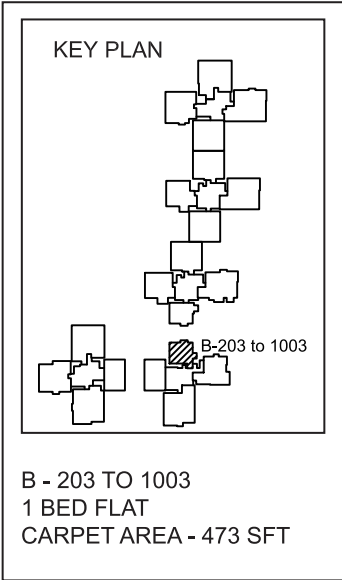

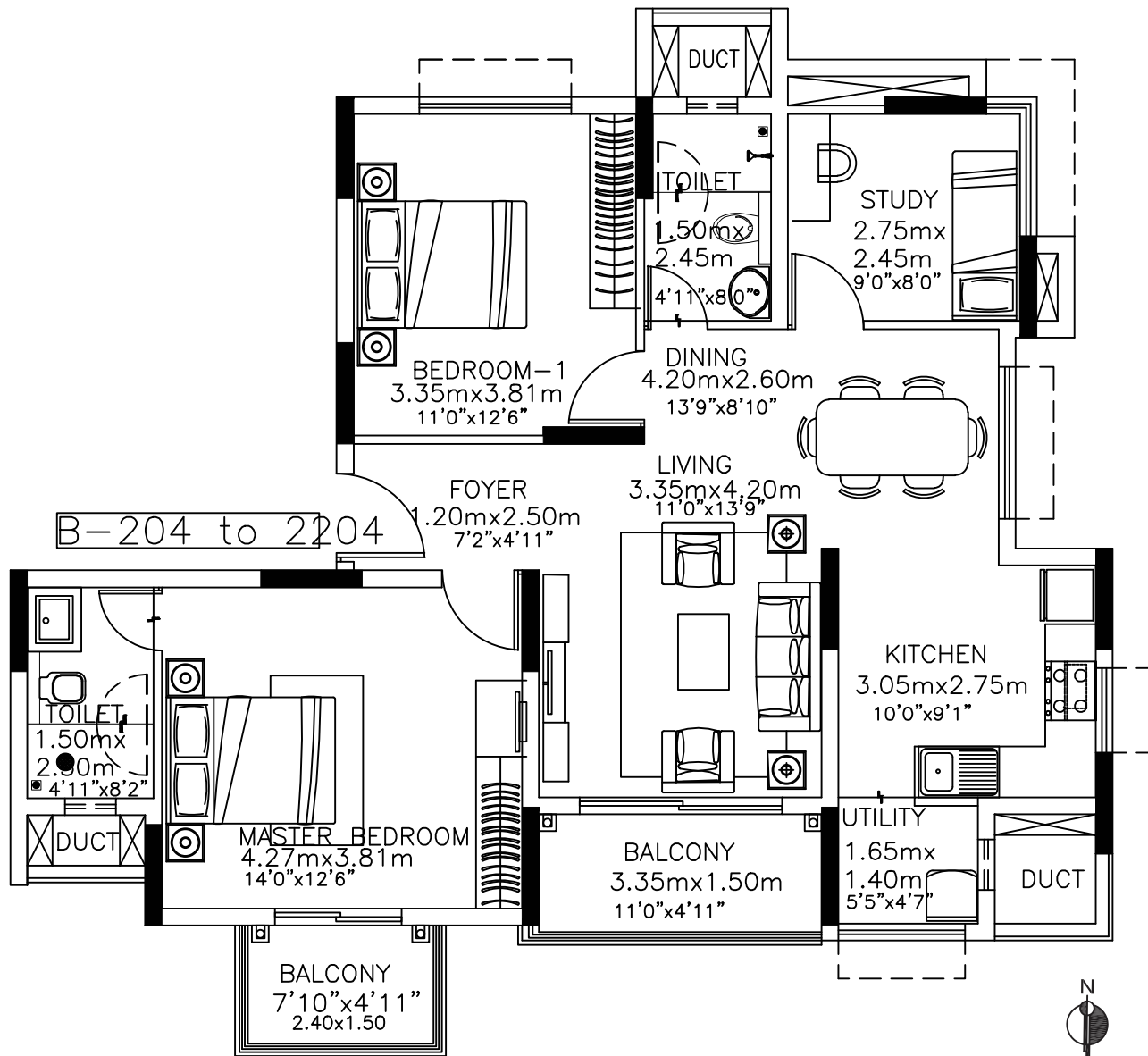

B 204 TO 2204 : 2 BED + STUDY FLAT

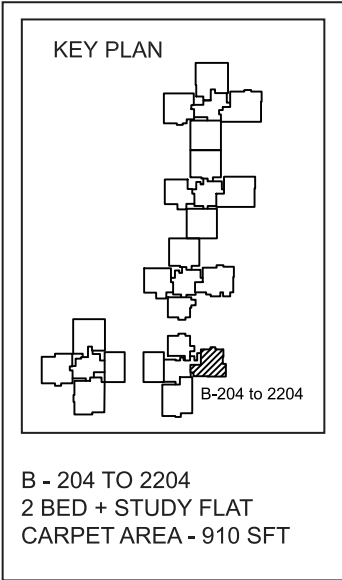

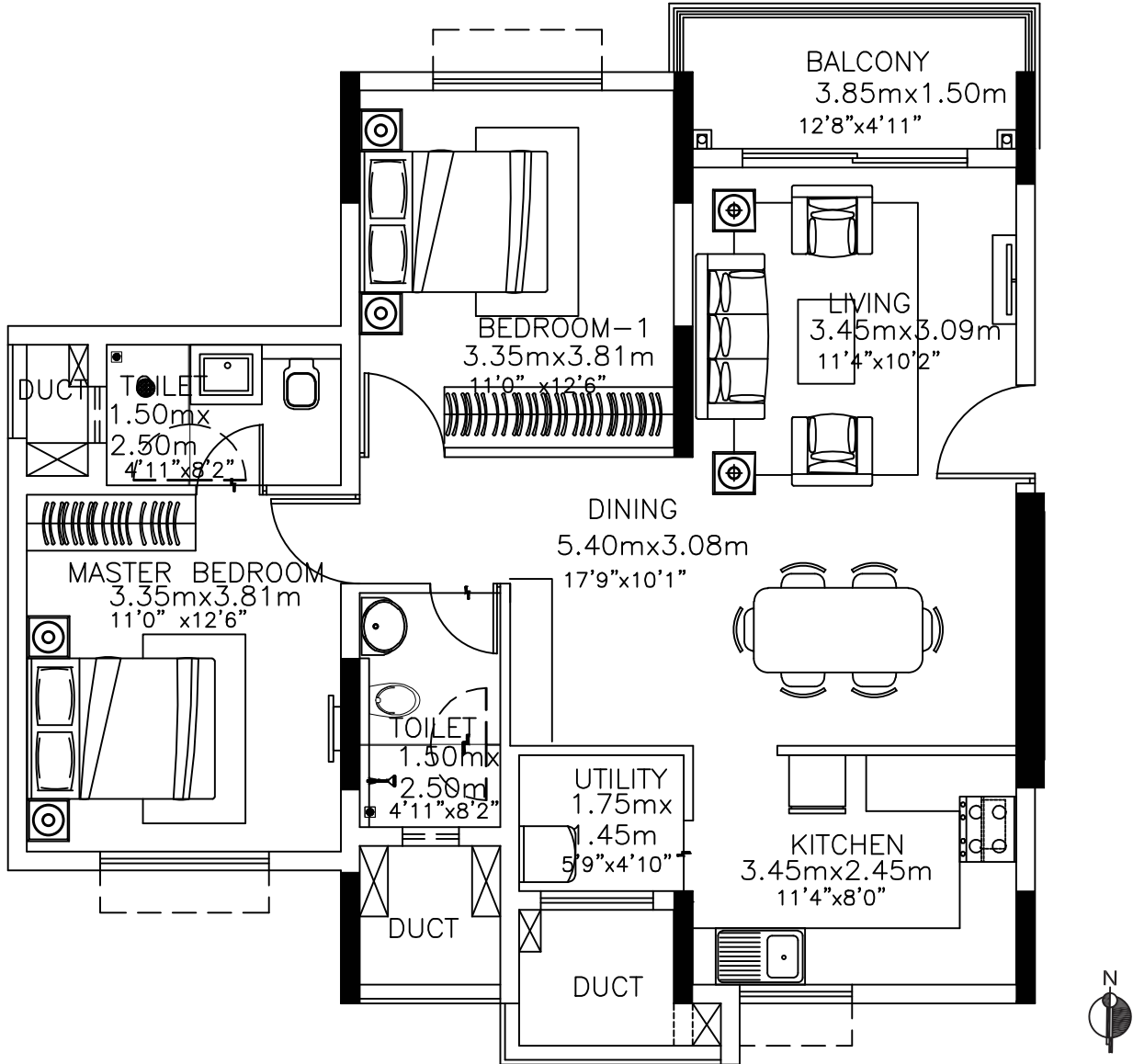

B 1202 TO 2202 : 2 BED FLAT

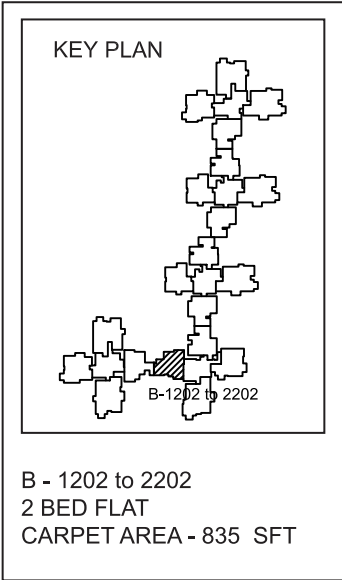

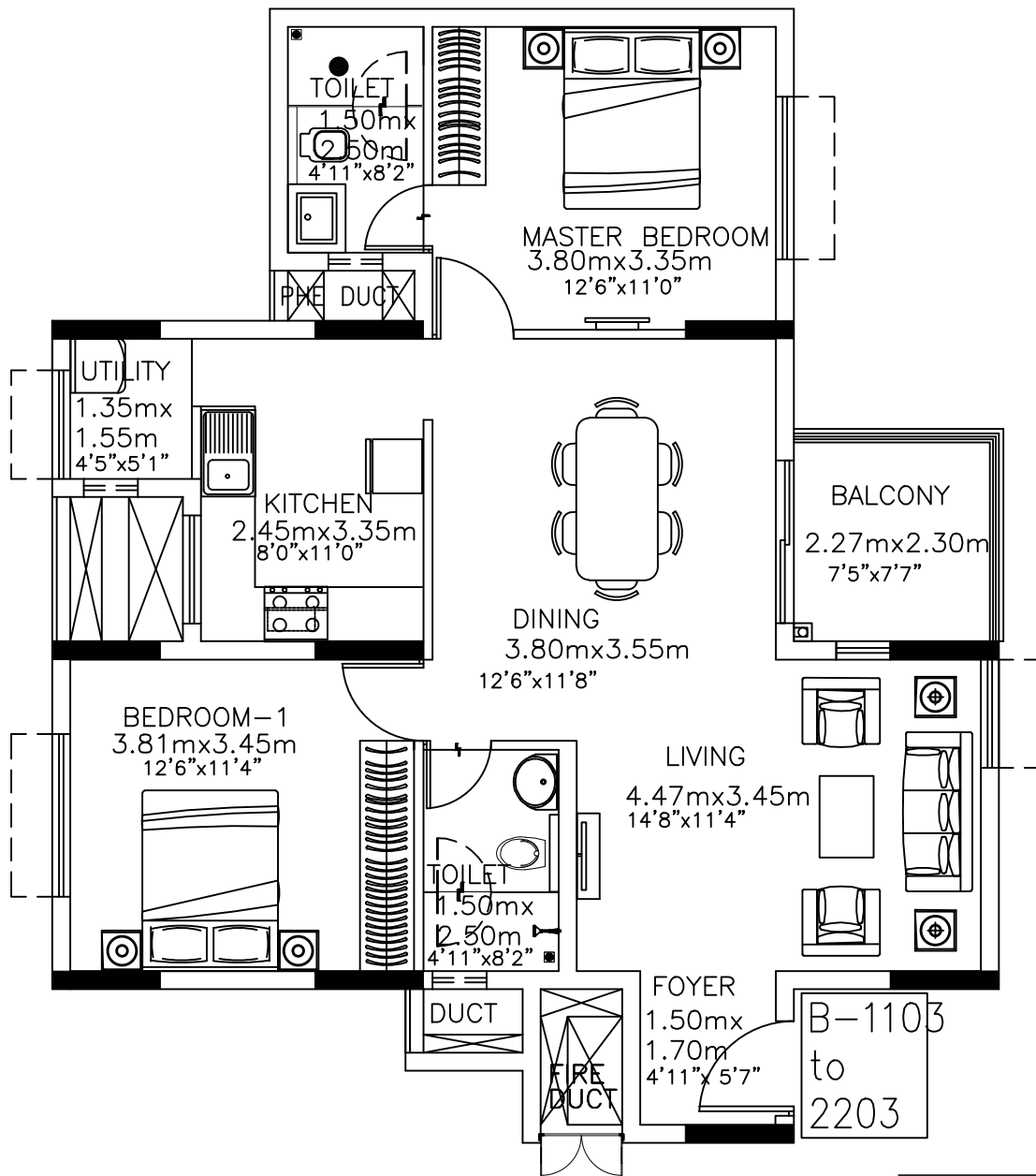

B 1103 TO 2203 : 2 BED FLAT

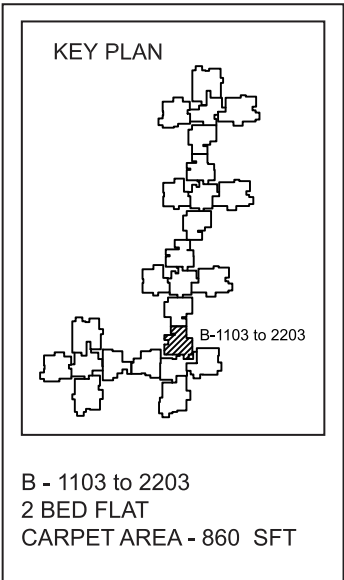

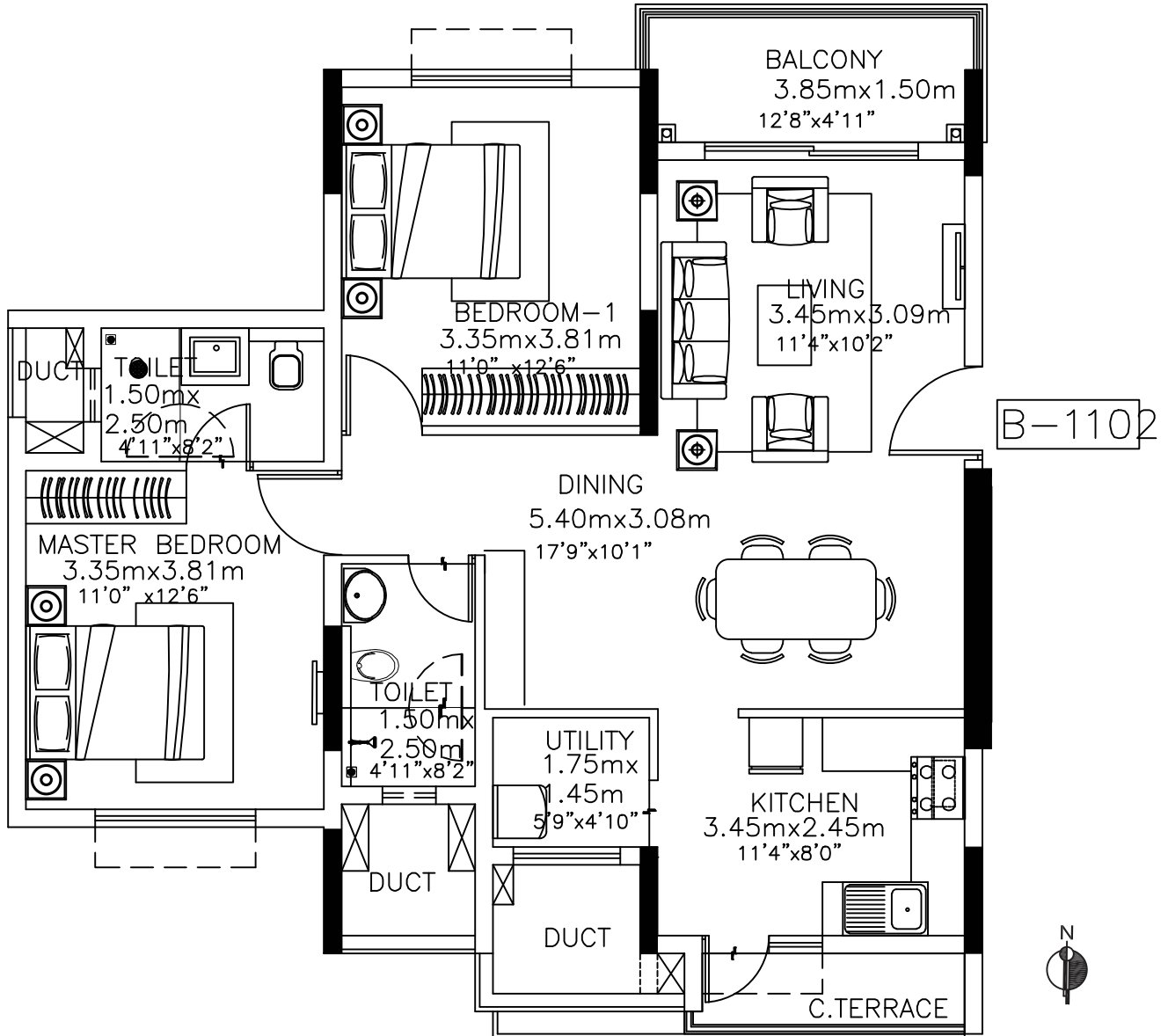

B 1102 : 2 BED FLAT

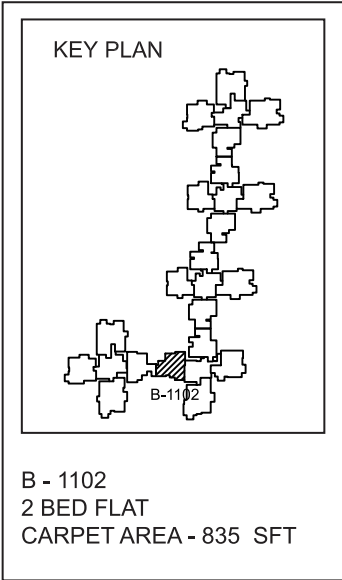

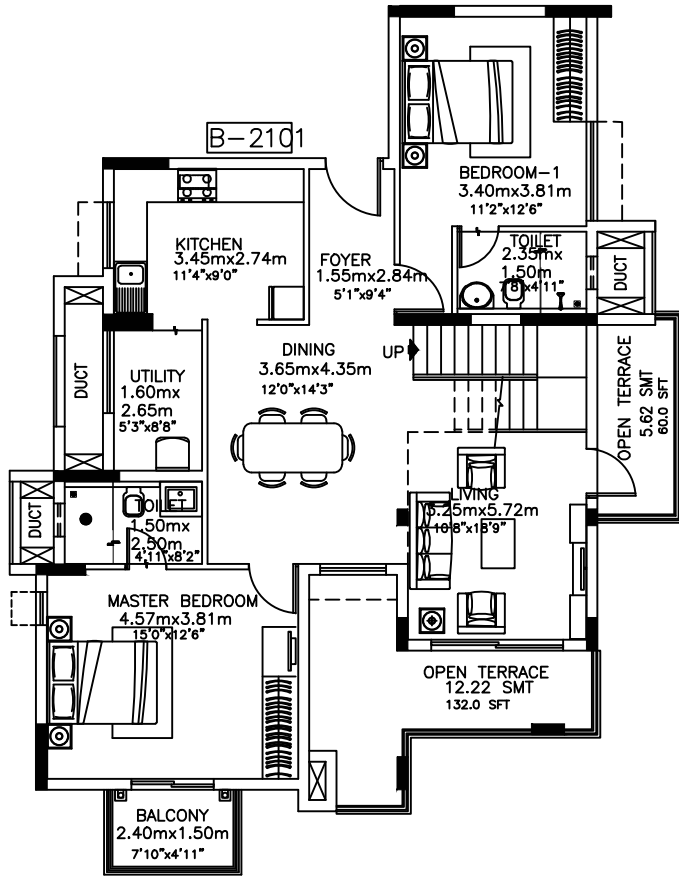

21ST FLOOR

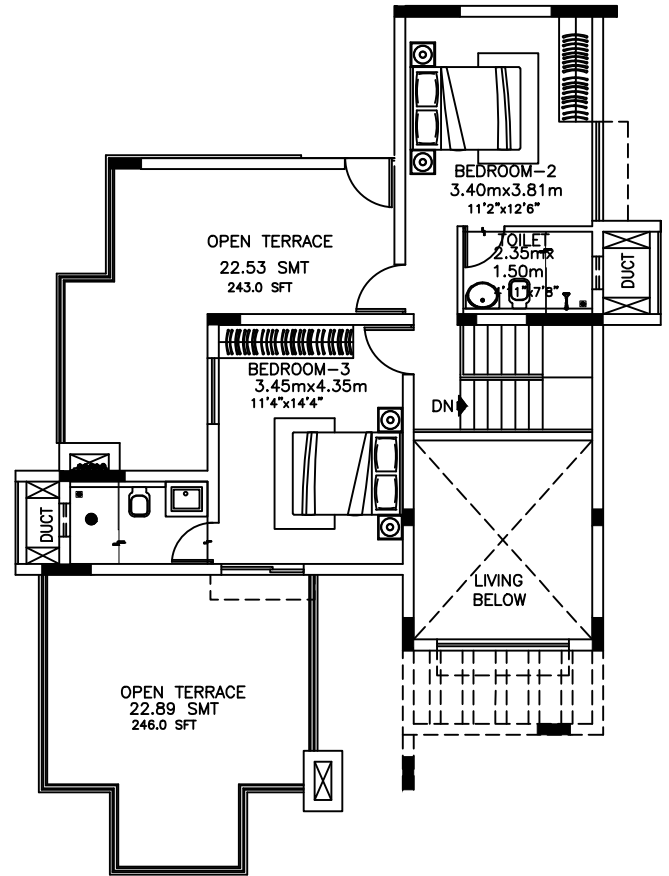

22ND FLOOR

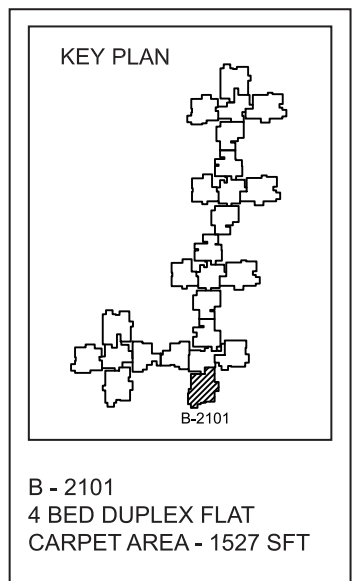

B 2101 : 4 BED DUPLEX FLAT

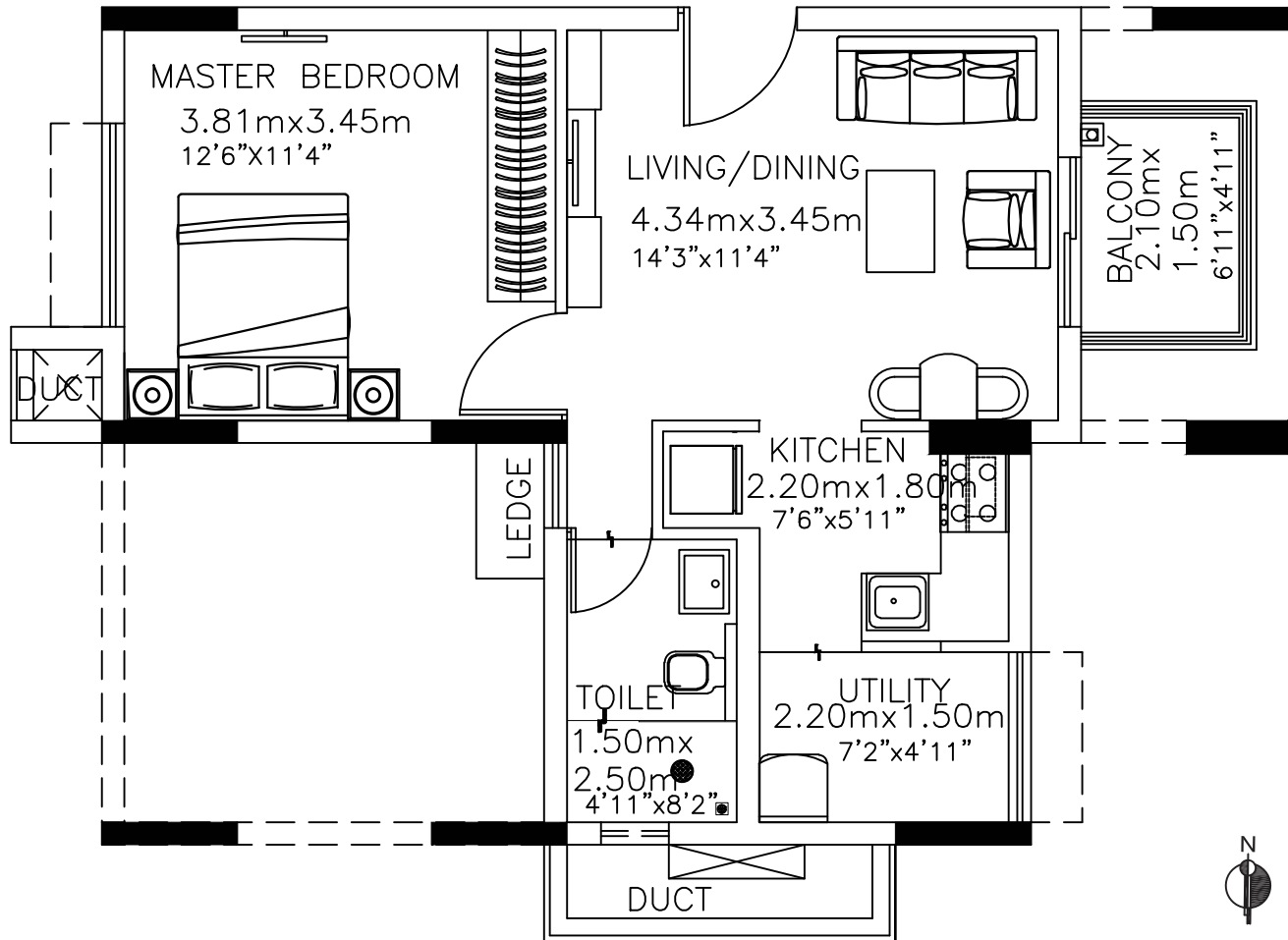

C 201 to 1001: 1 BED FLAT

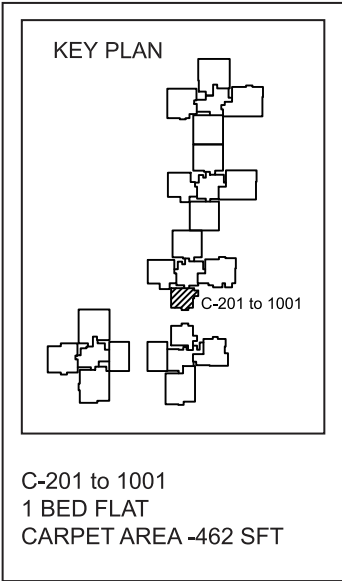

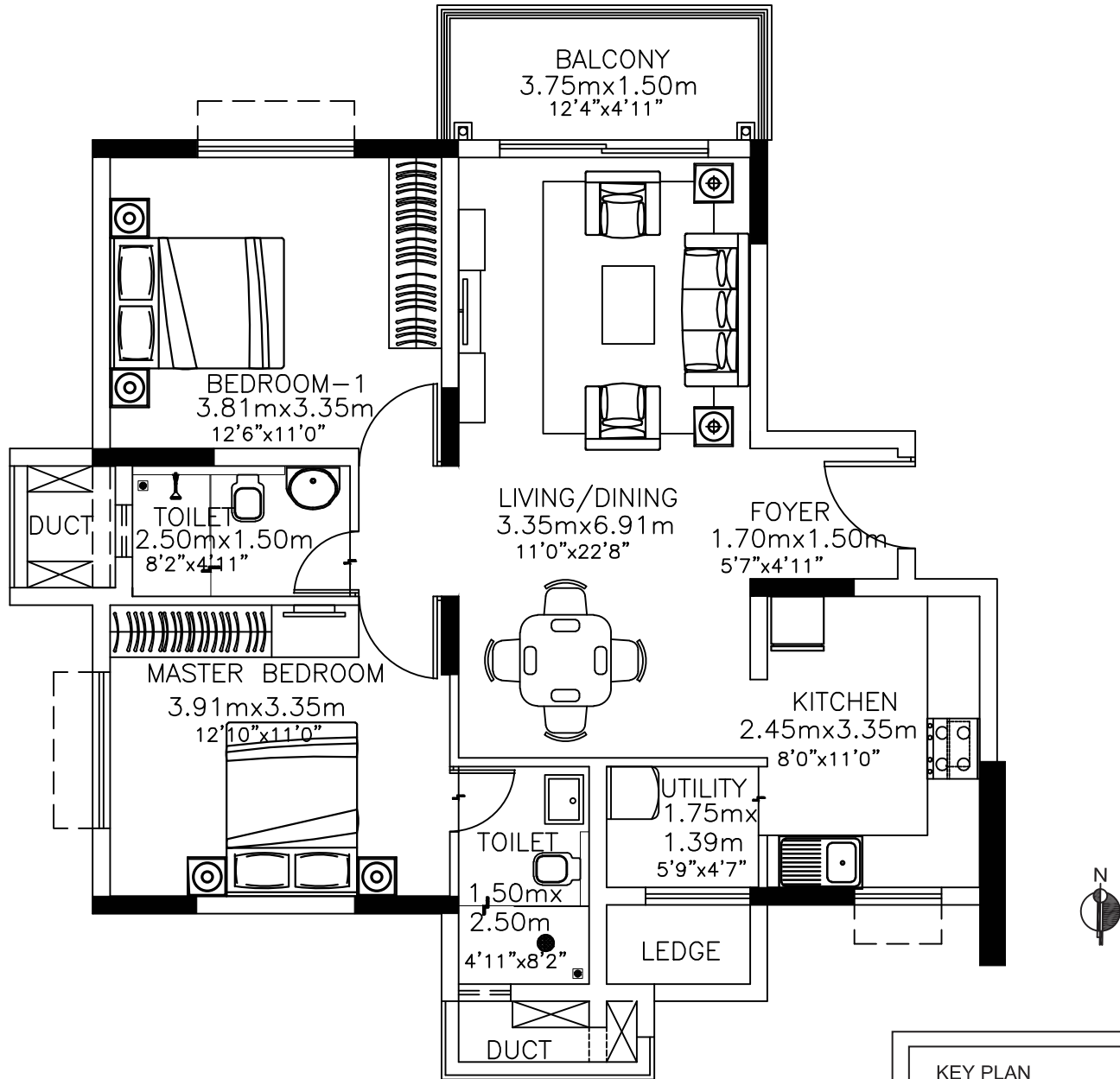

C 202 to 2202: 2 BED FLAT

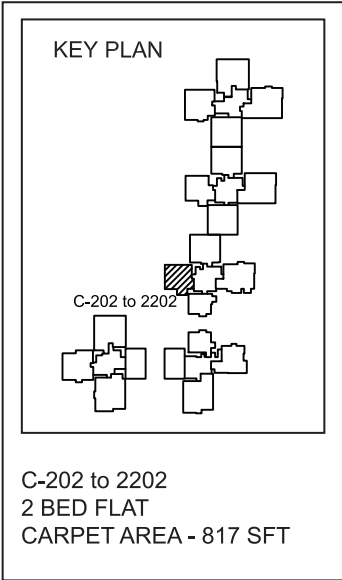

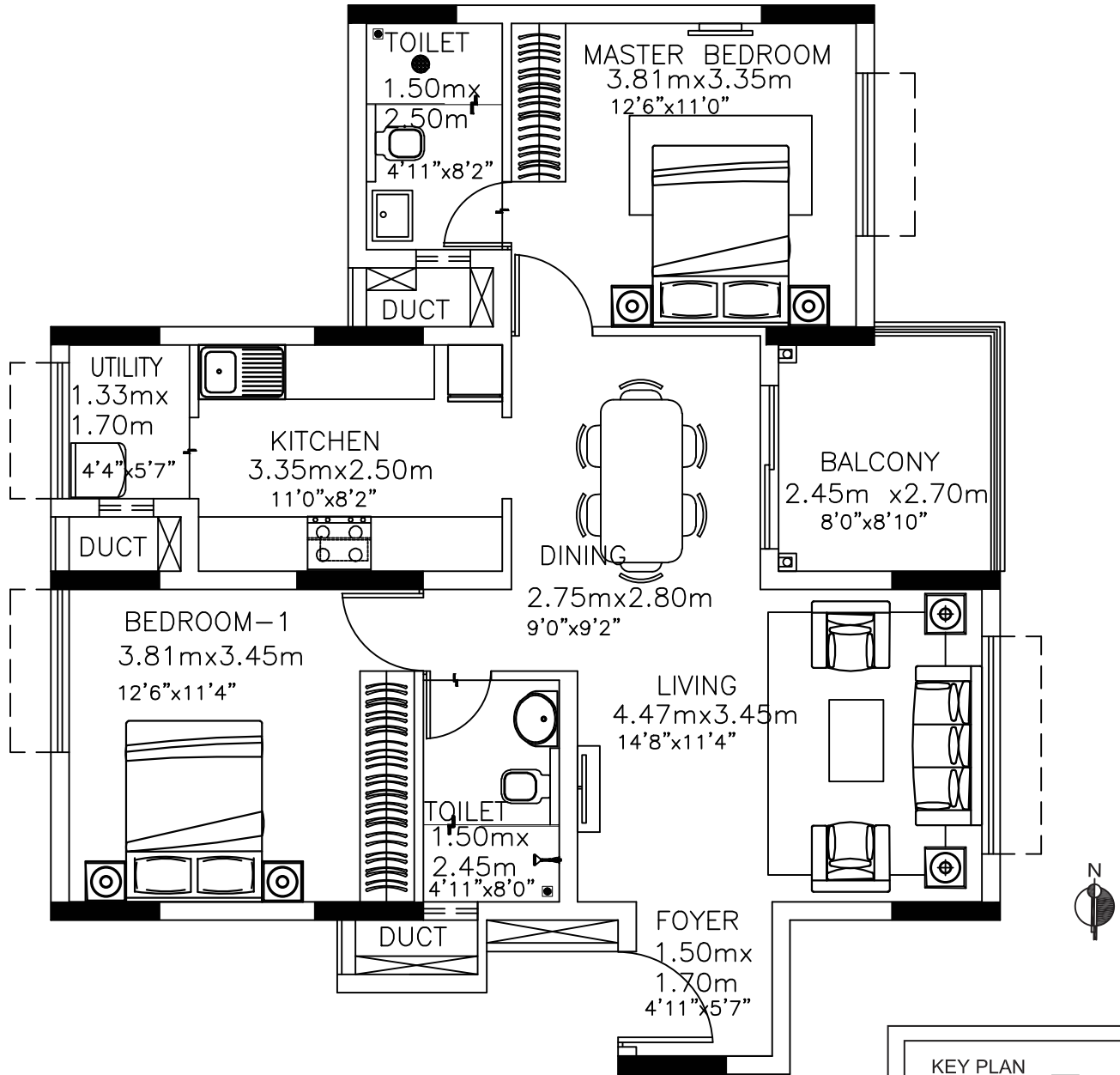

C 203 to 2203 : 2 BED FLAT

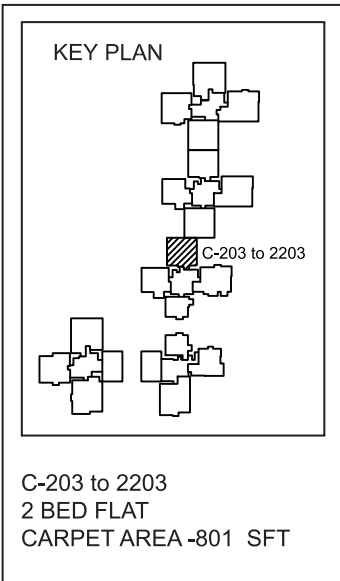

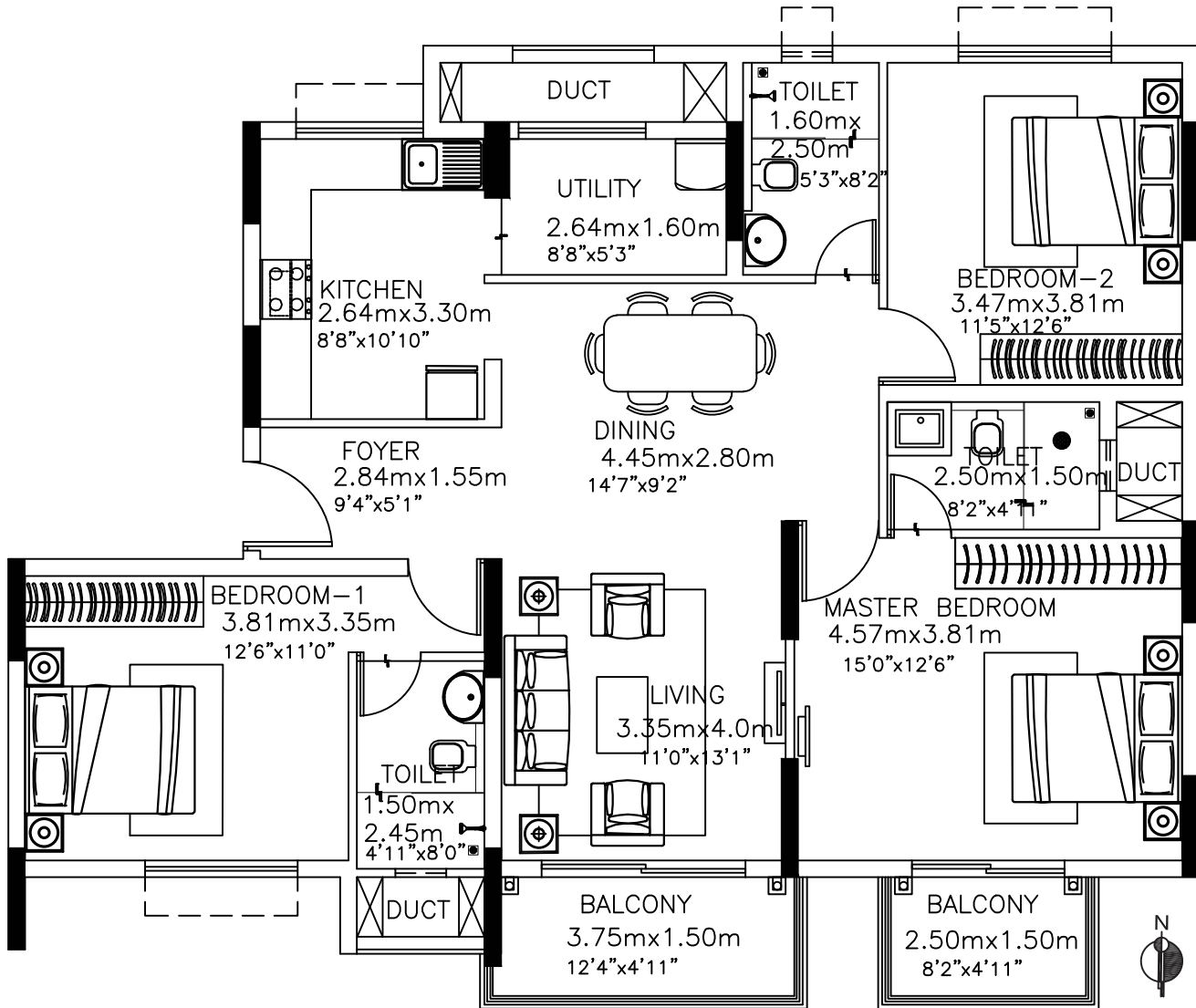

C 204 to 504: 3 BED FLAT

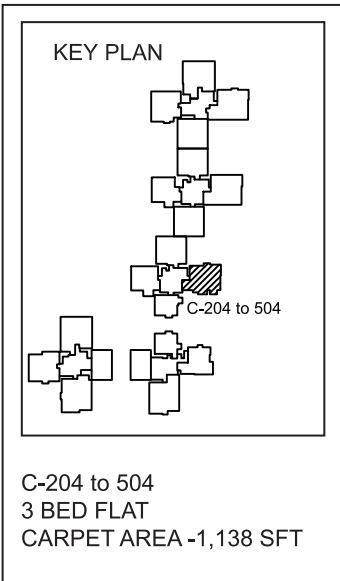

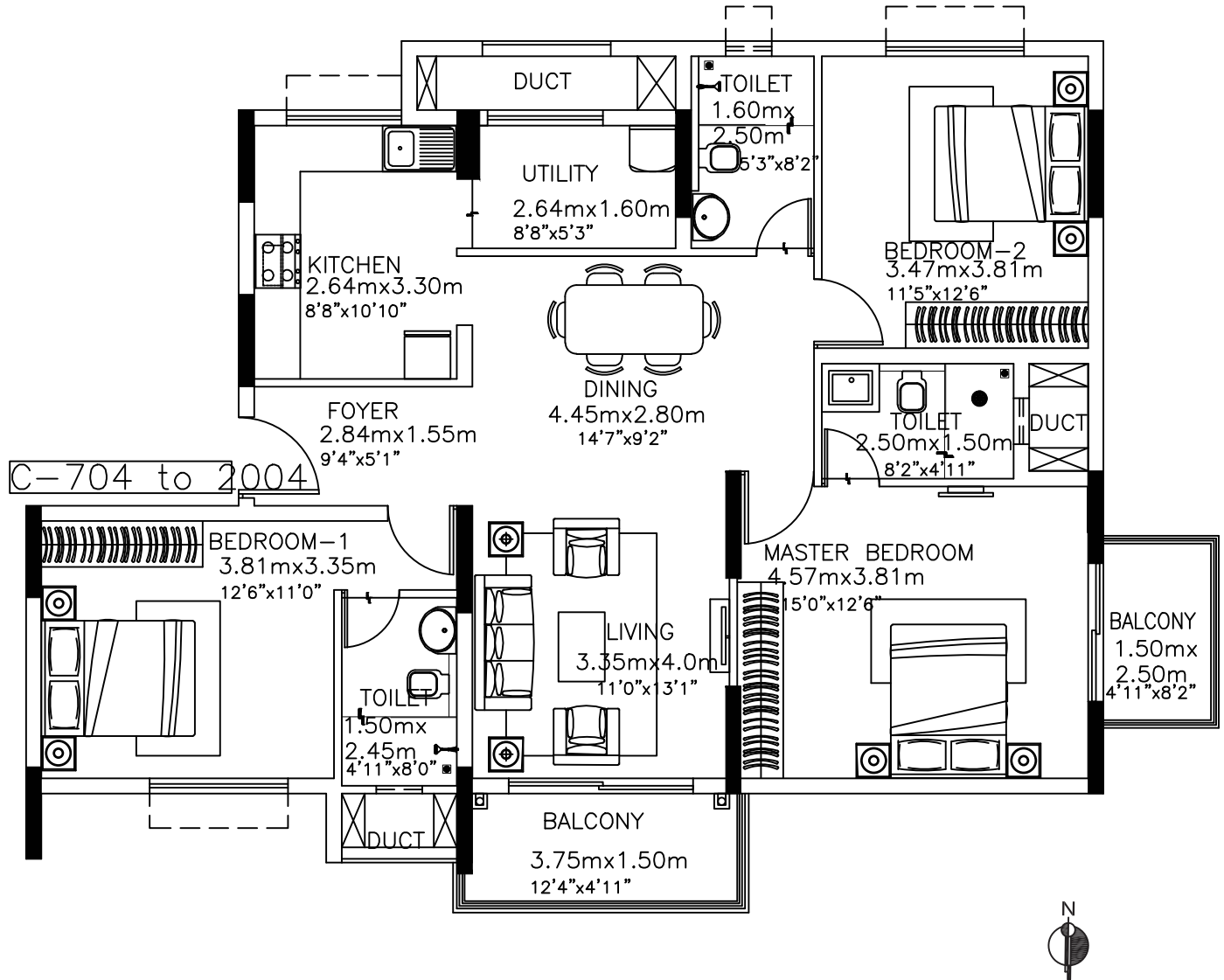

C-704 to 2004



C 704 TO 2004 : 3 BED FLAT

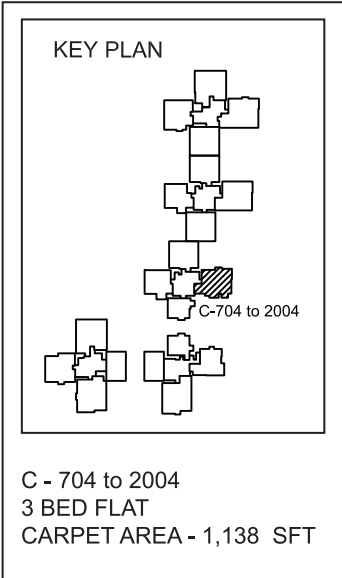

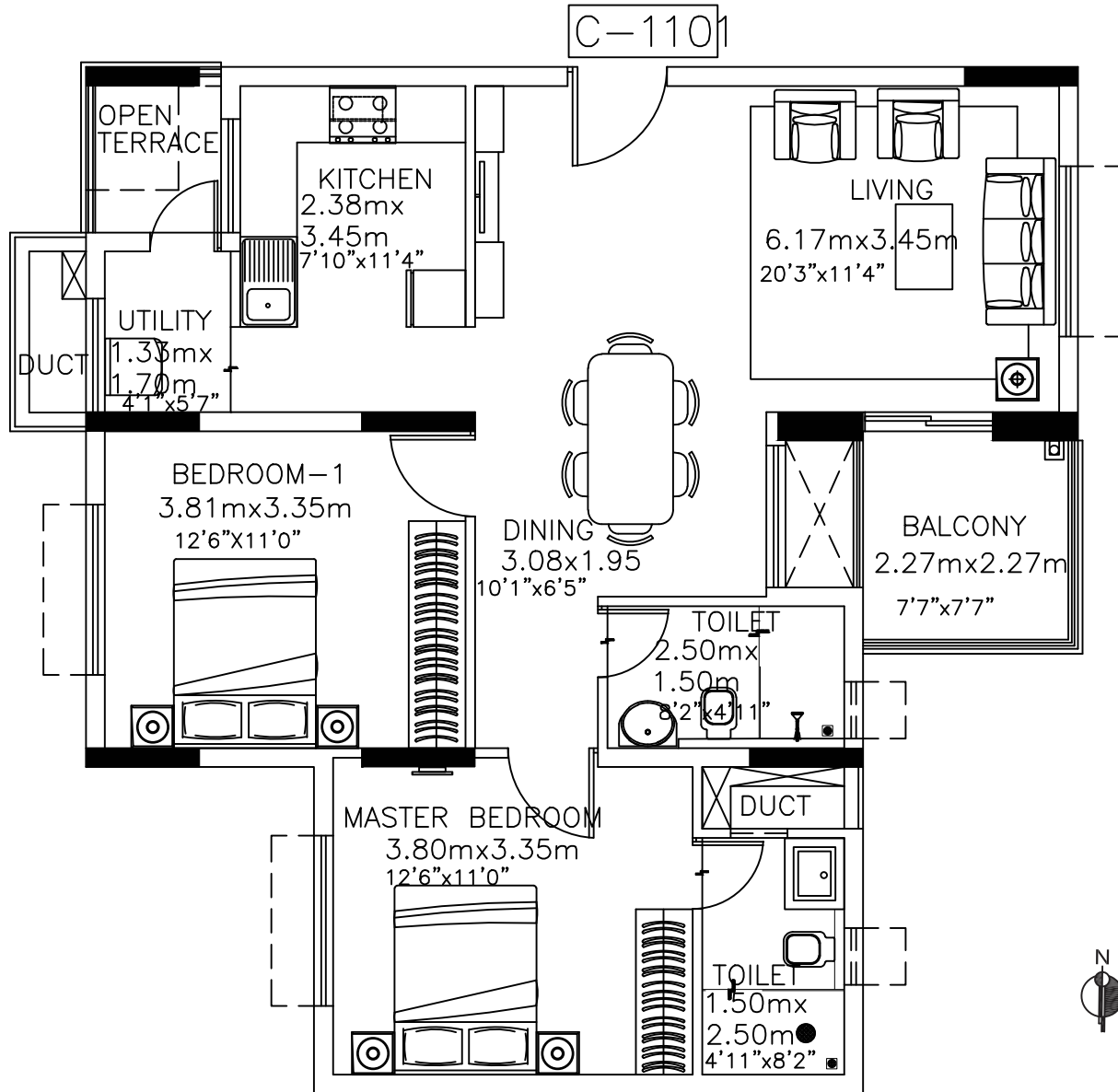

C 1101 : 2 BED FLAT

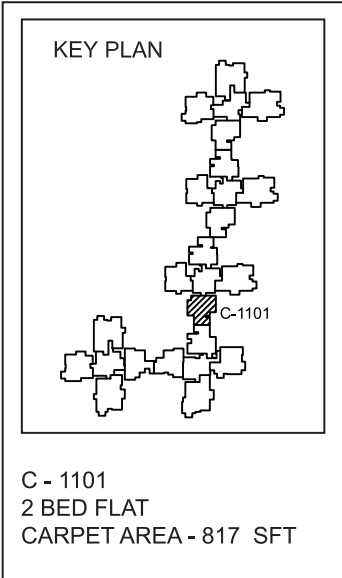

C-1201 to 2201

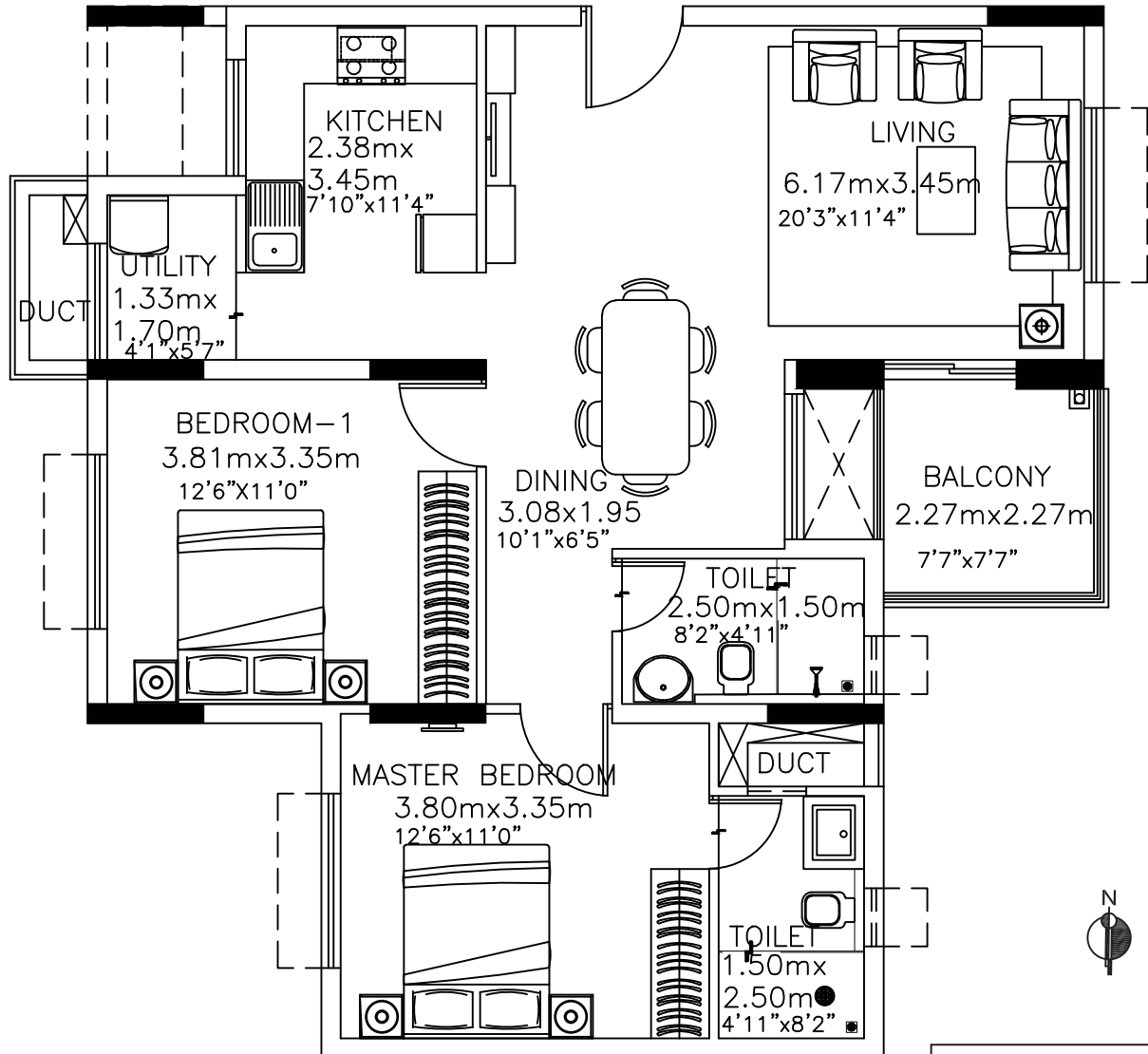

C 1201 to 2201 : 2 BED FLAT

KEY PLAN

C-1201 to 2201

C - 1201-2201
2 BED FLAT
CARPET AREA - 817 SFT

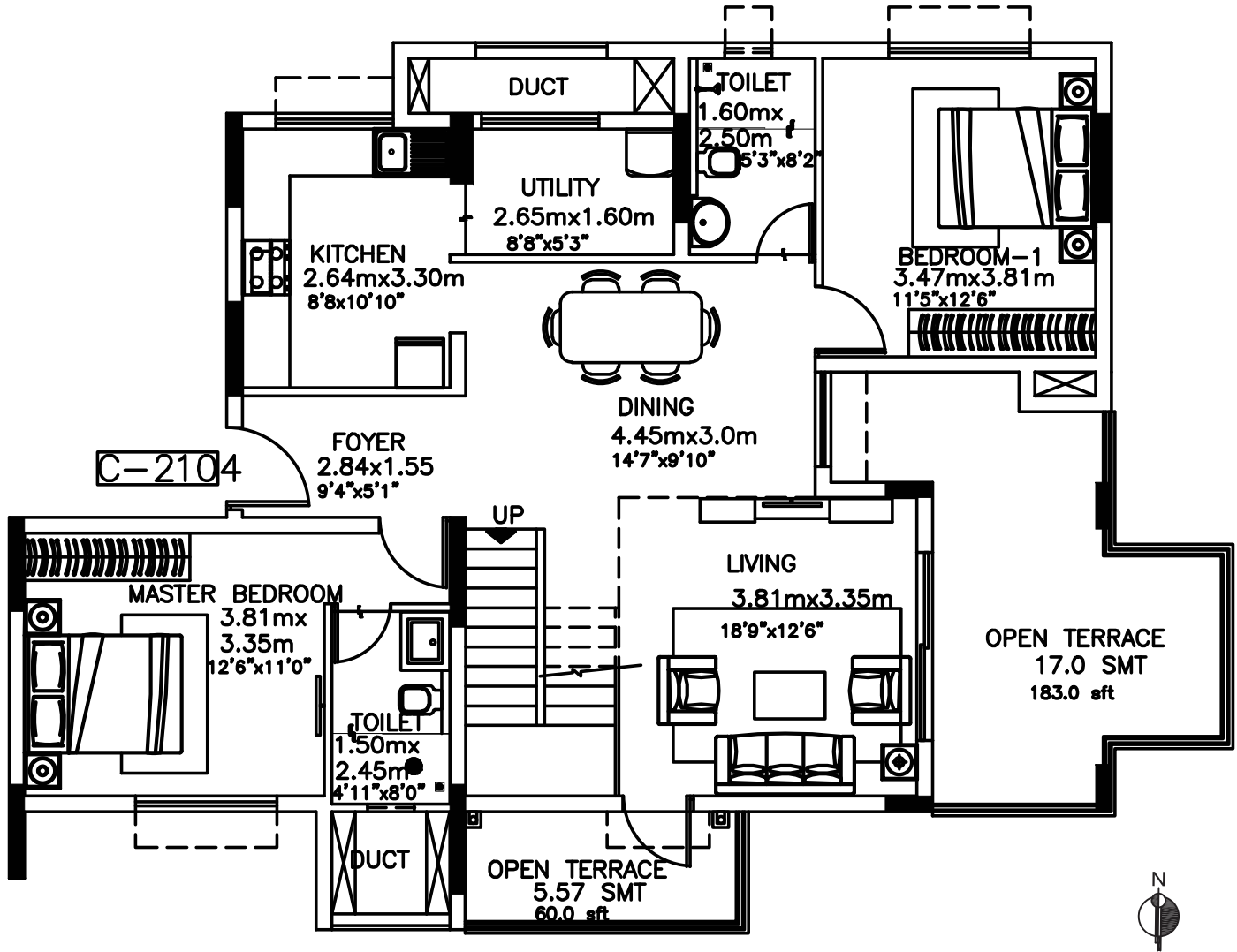

21ST FLOOR

C 2104 : 4 BED DUPLEX FLAT

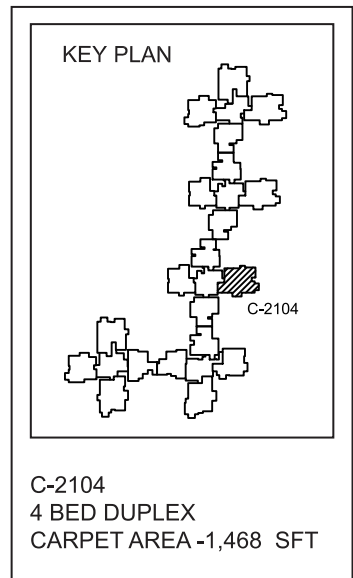

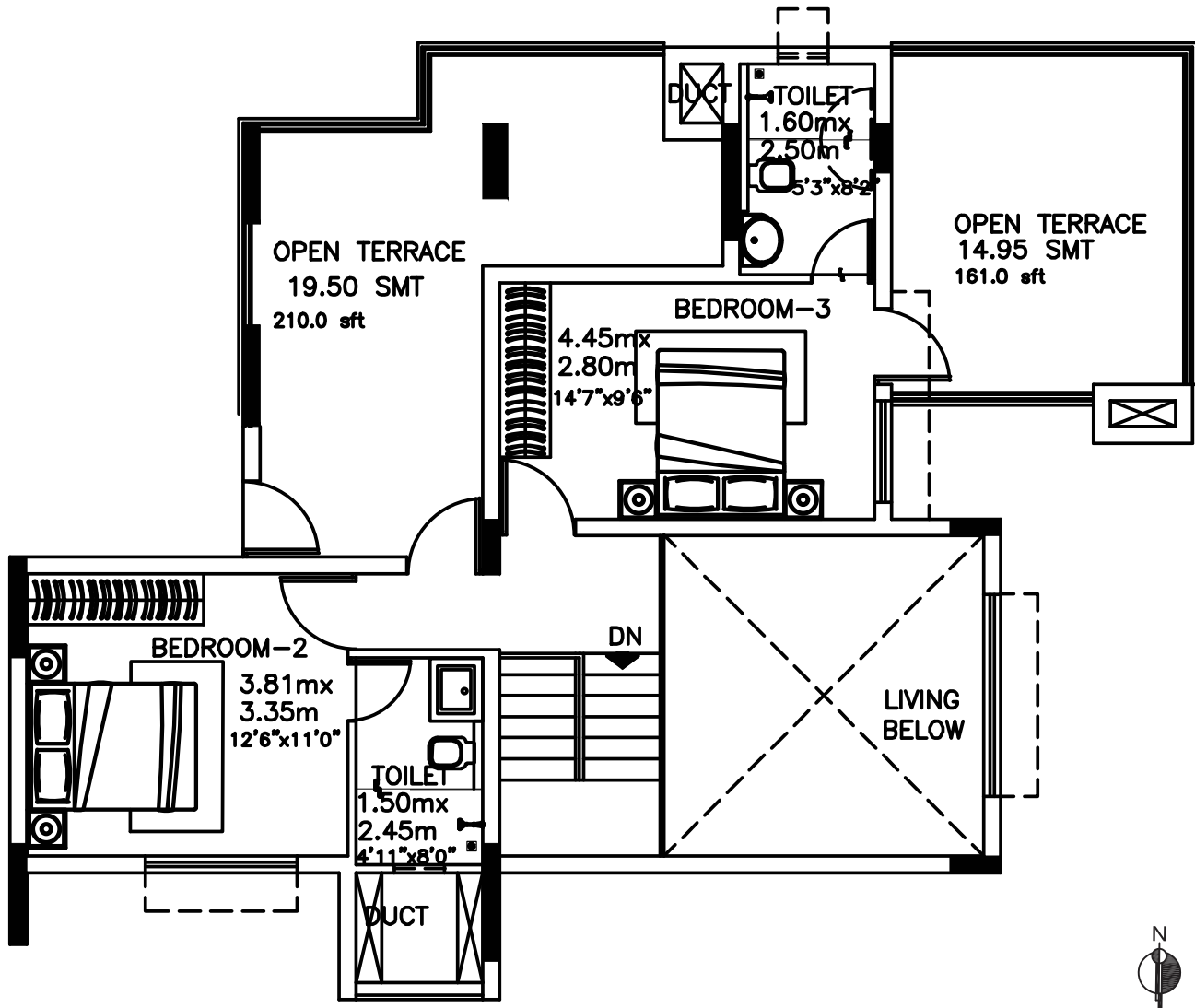

22ND FLOOR

C 2104 : 4 BED DUPLEX FLAT

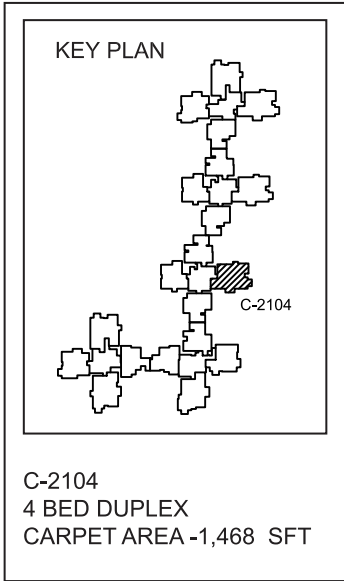

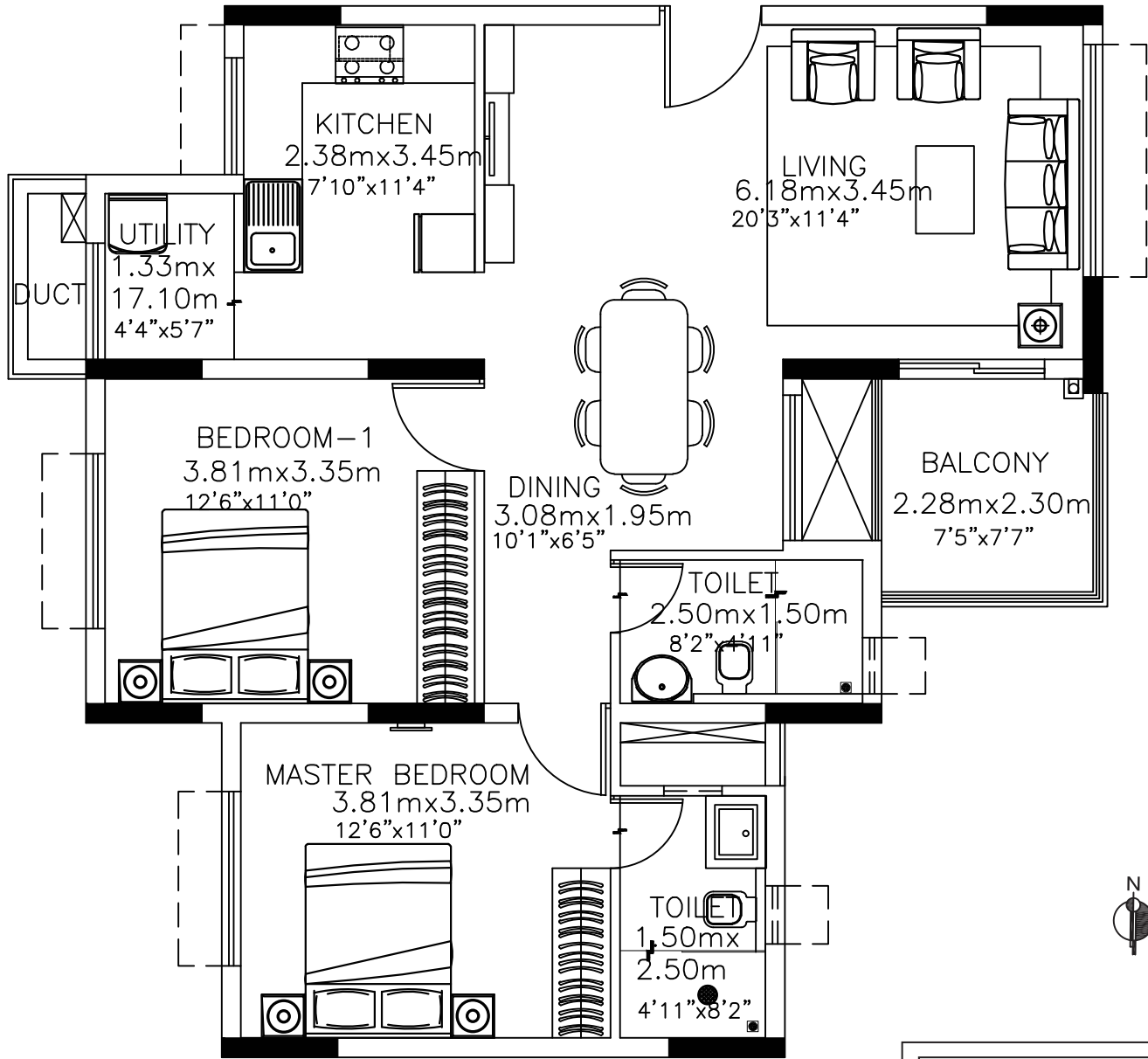

D 201 to 2201 : 2 BED FLAT

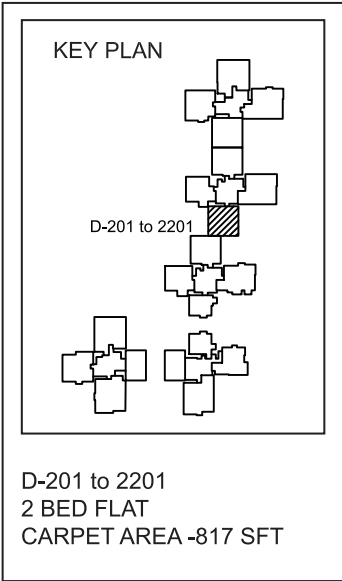

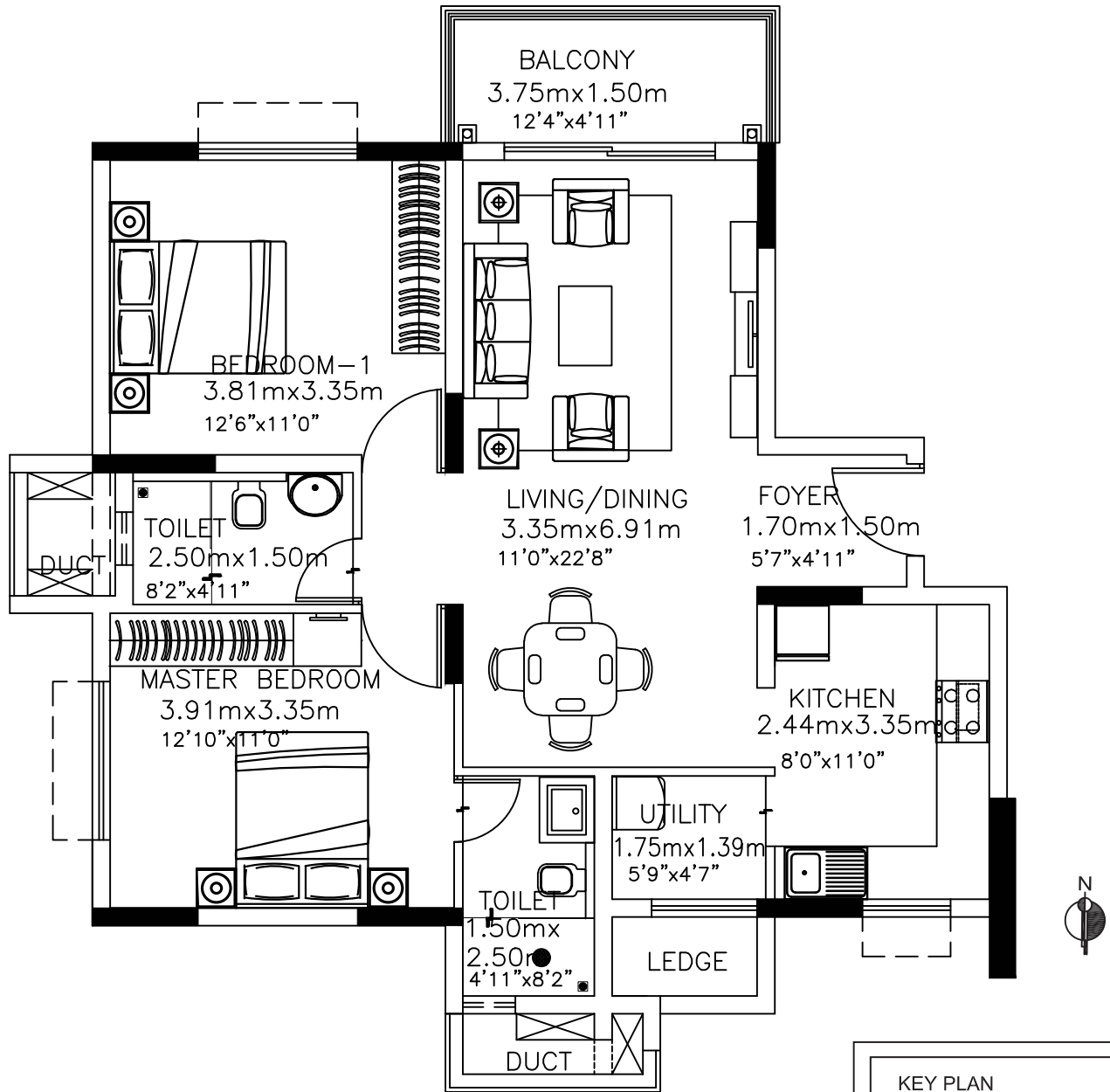

D 202 to 2202 : 2 BED FLAT

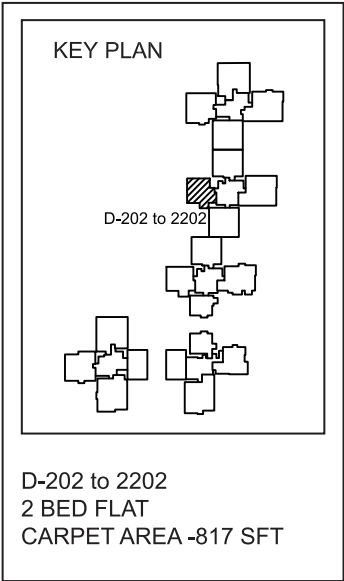

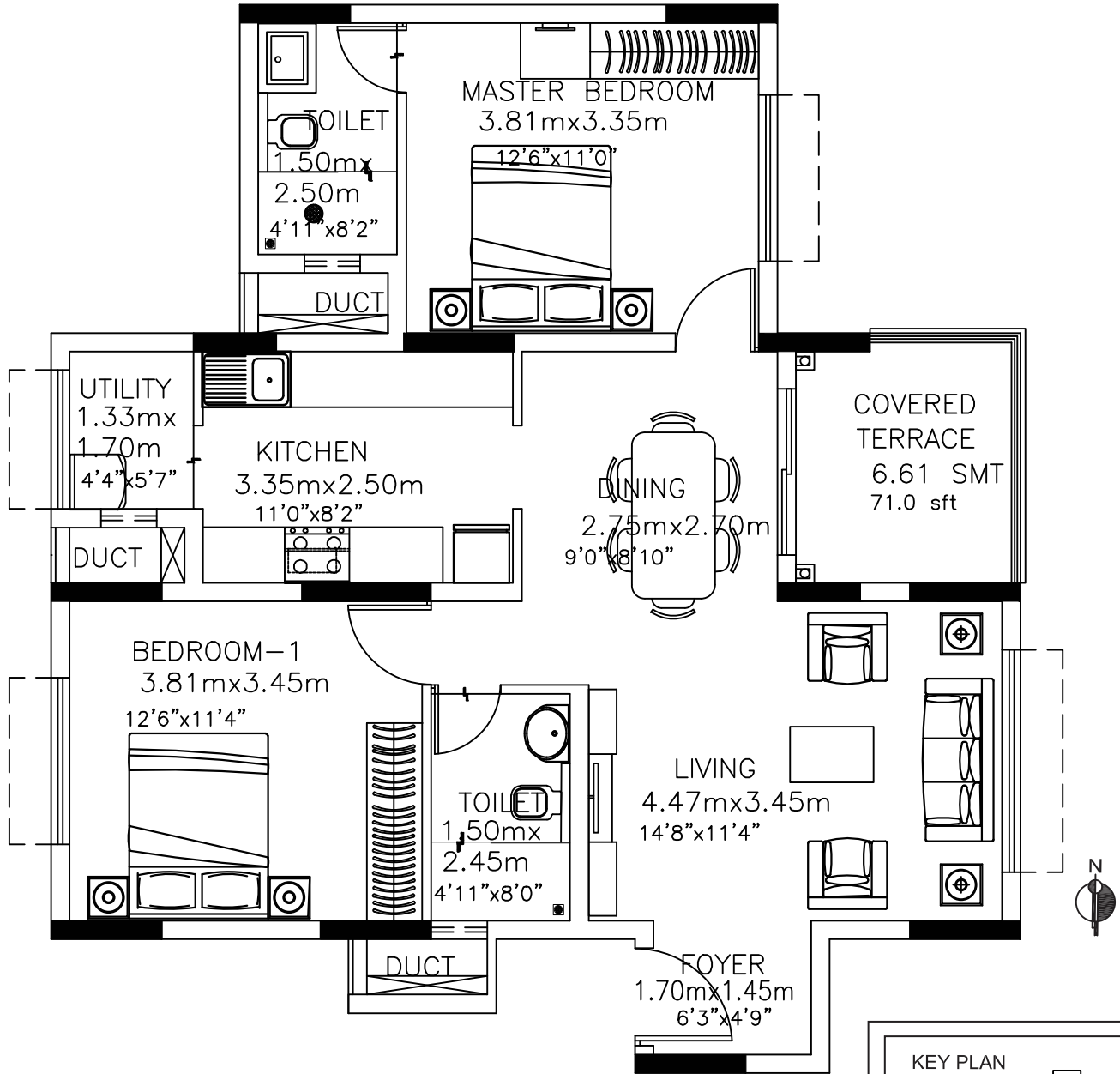

D 203 to 2203 : 2 BED FLAT

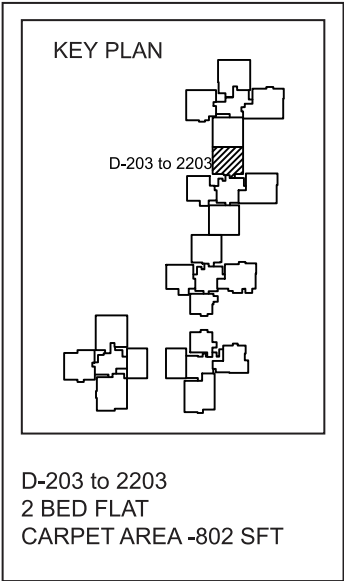

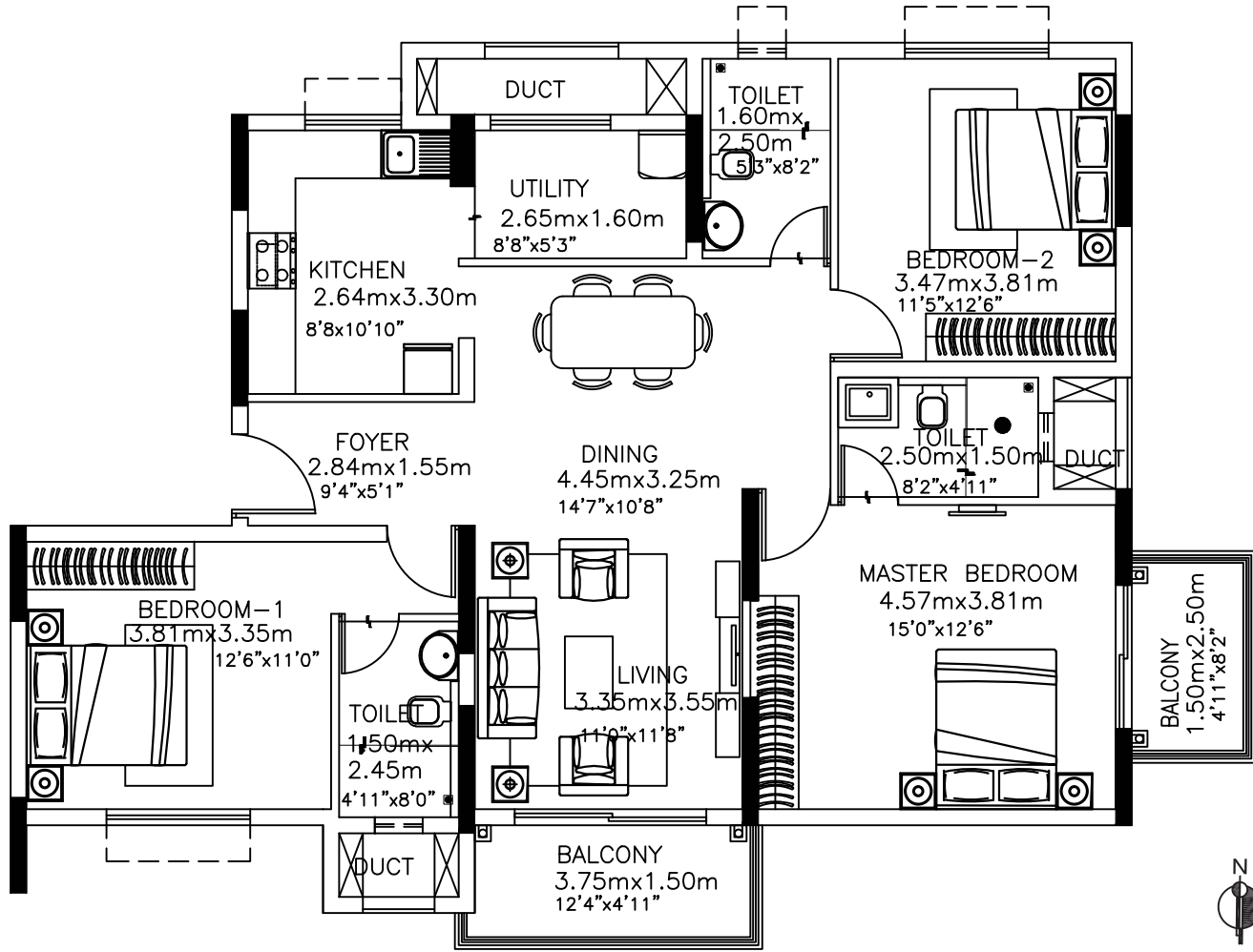

D 204 to 2004 : 3 BED FLAT

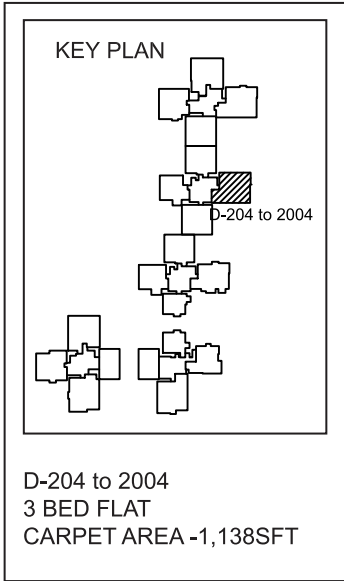

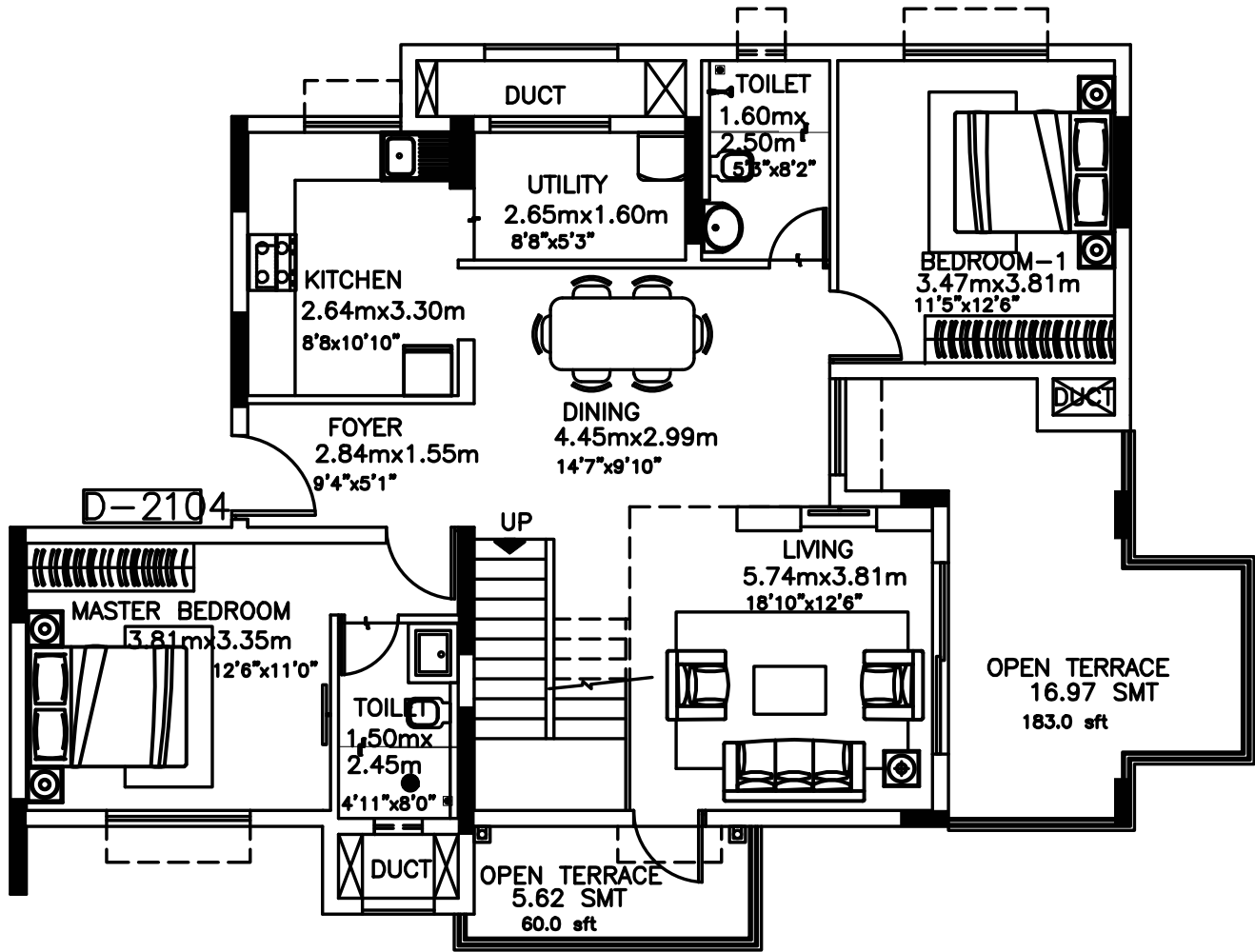

21ST FLOOR



D 2104 : 4 BED DUPLEX FLAT

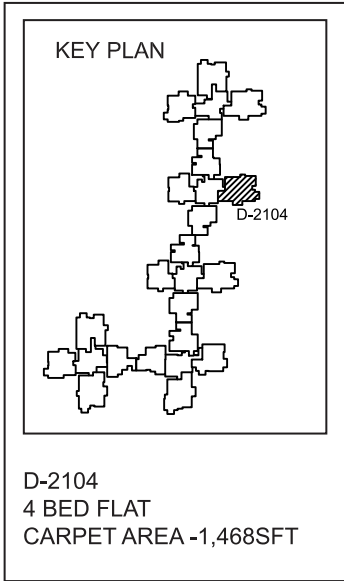

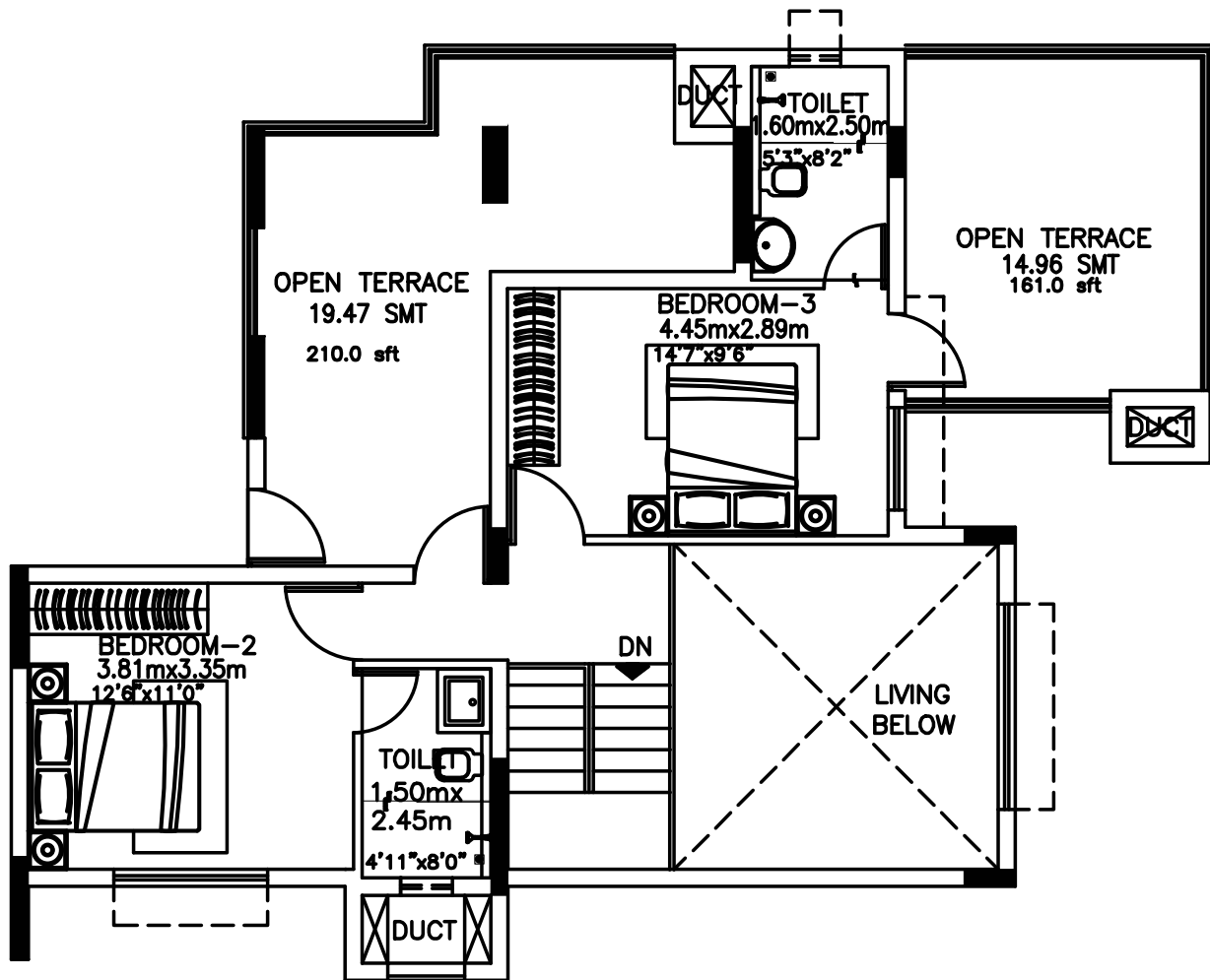

22ND FLOOR



D 2104 : 4 BED DUPLEX FLAT

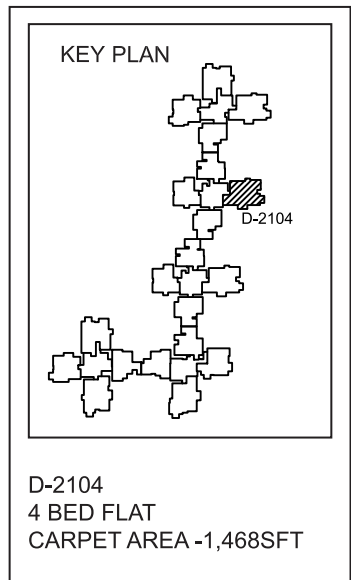

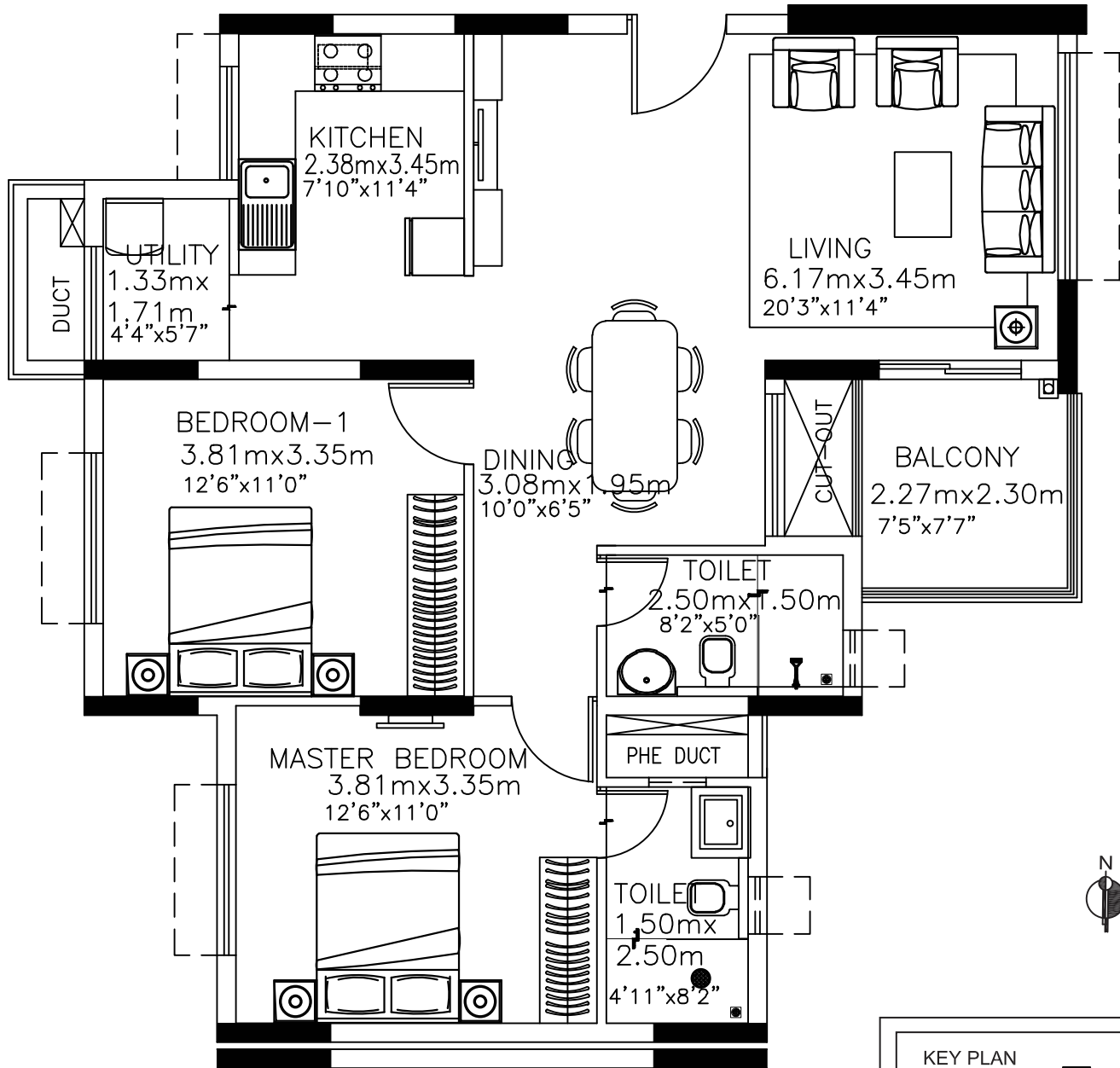

E 201 to 2201 : 2 BED FLAT

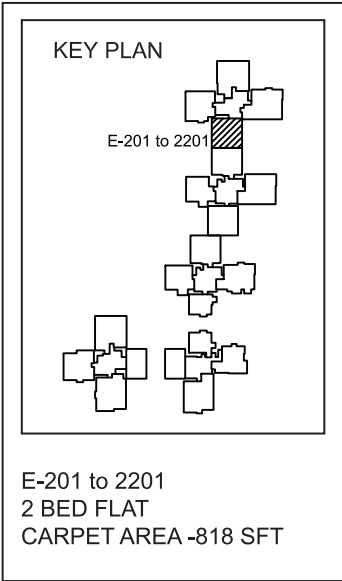

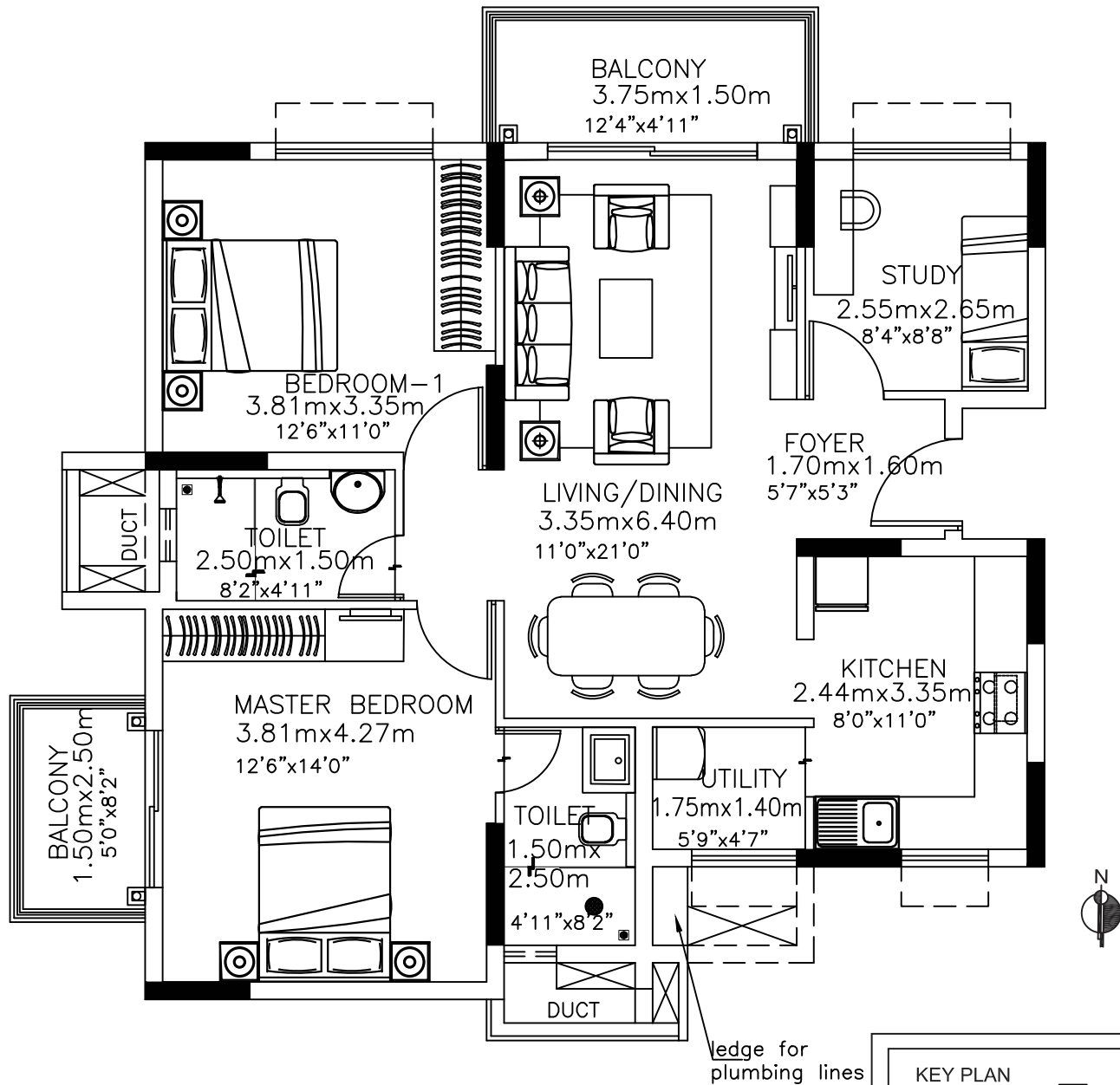

E 202 to 2202 : 2 BED+STUDY FLAT

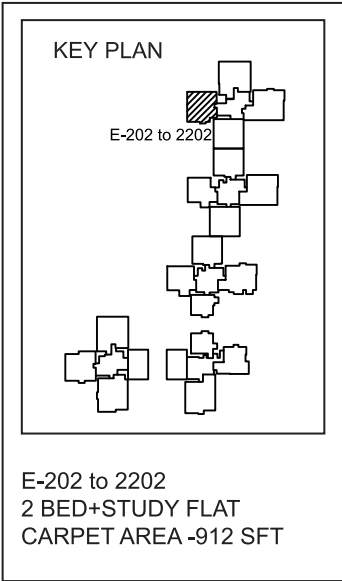

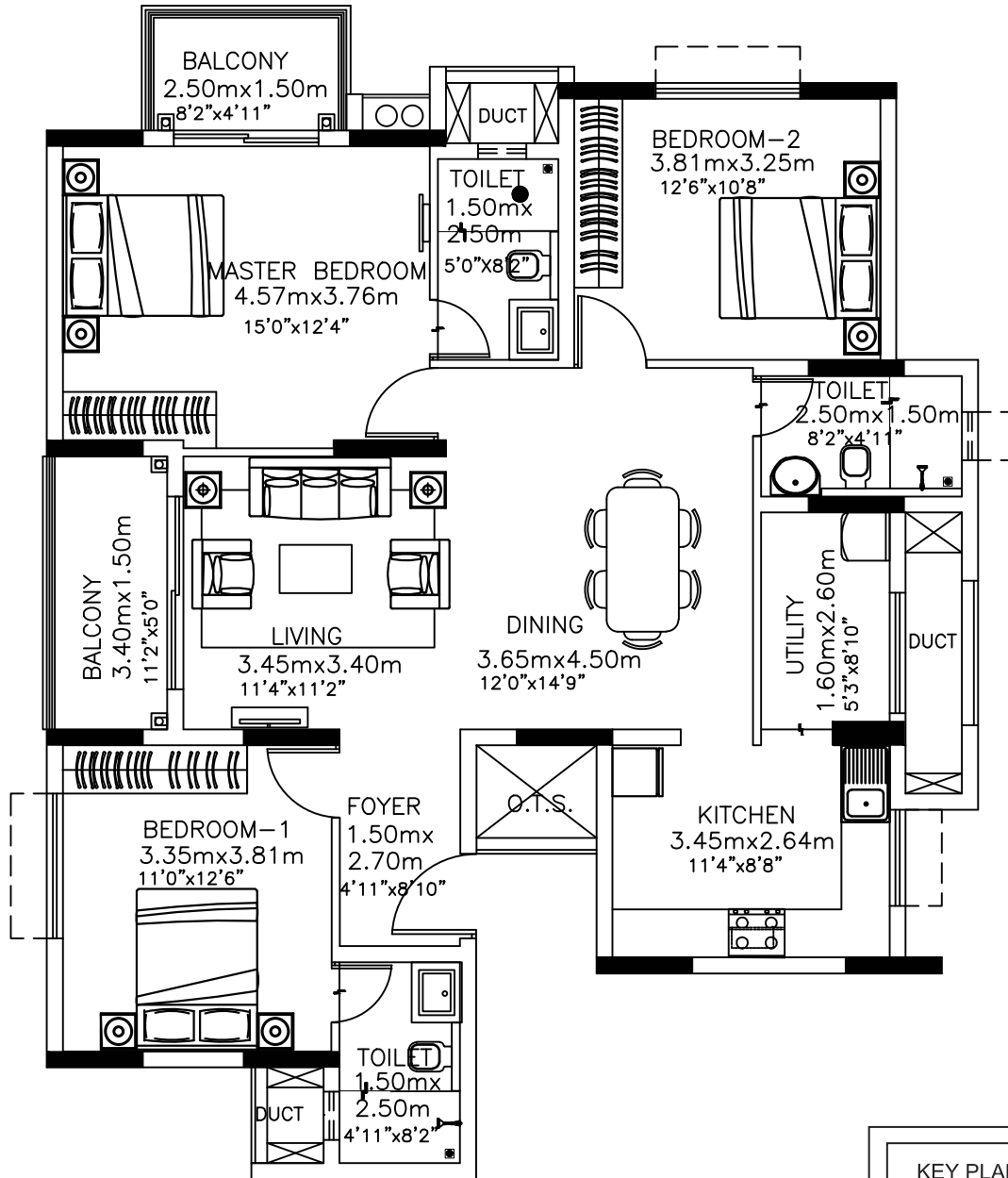

E 203 to 2003 : 2 BED FLAT

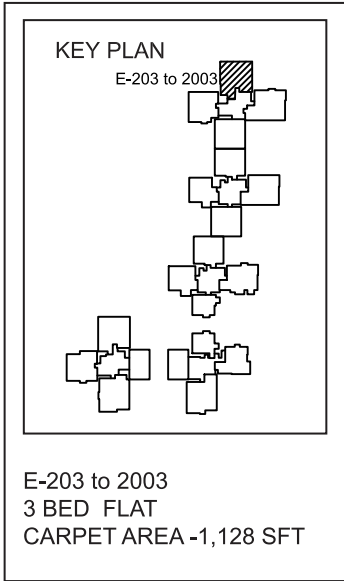

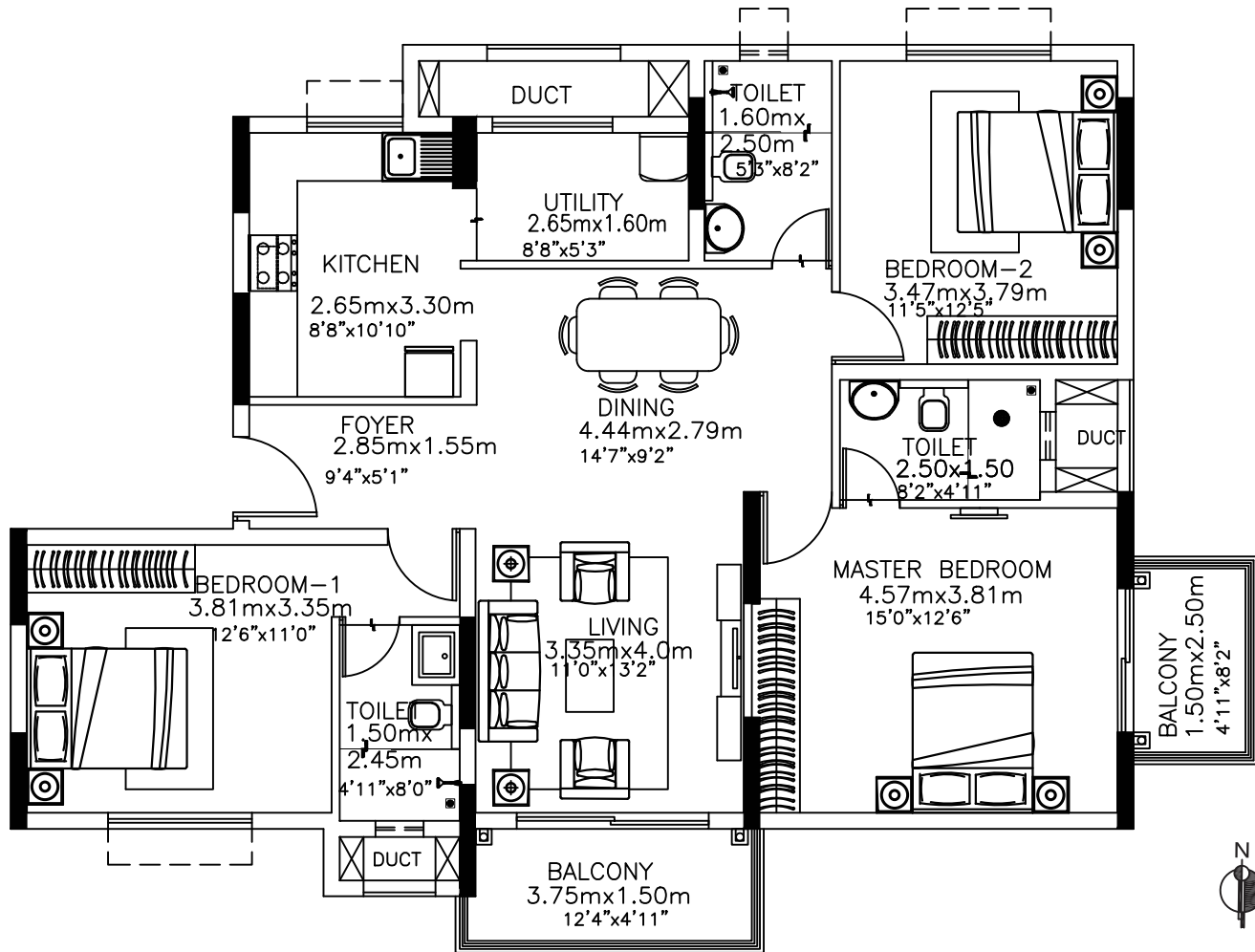

E 204 to 2004 : 3 BED FLAT

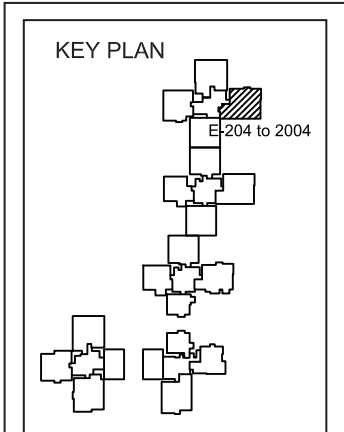

E-204 to 2004
 3 BED FLAT
 CARPET AREA -1,138 SFT

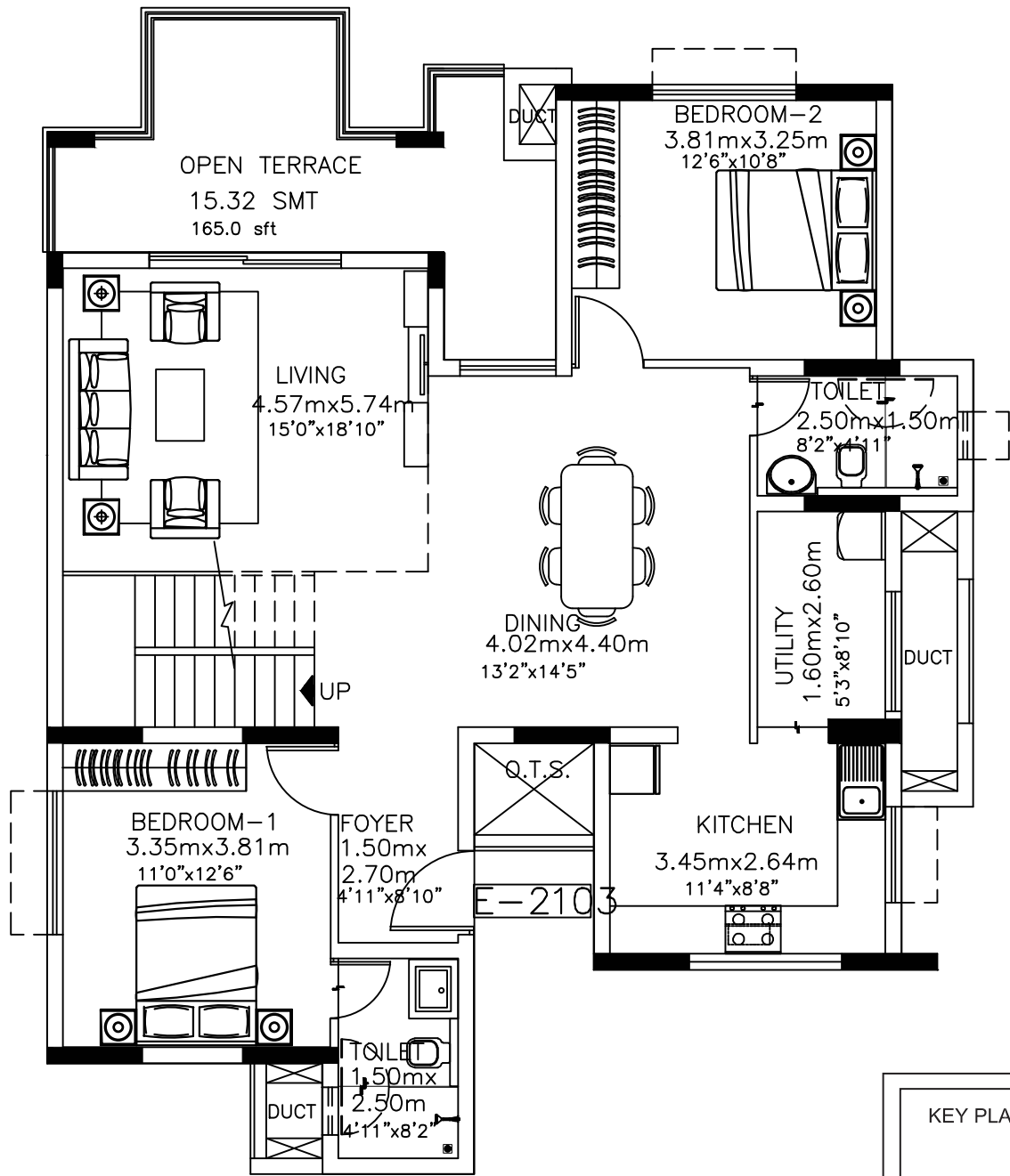

21ST FLOOR

E 2103 : 4 BED DUPLEX FLAT

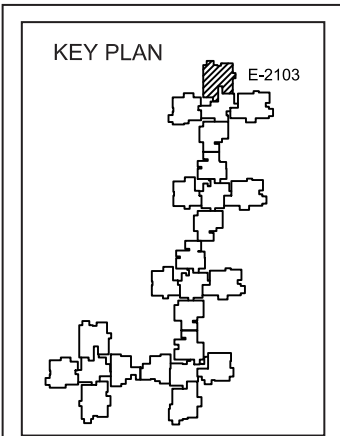

E-2103
4 BED DUPLEX FLAT
CARPET AREA -1,631 SFT

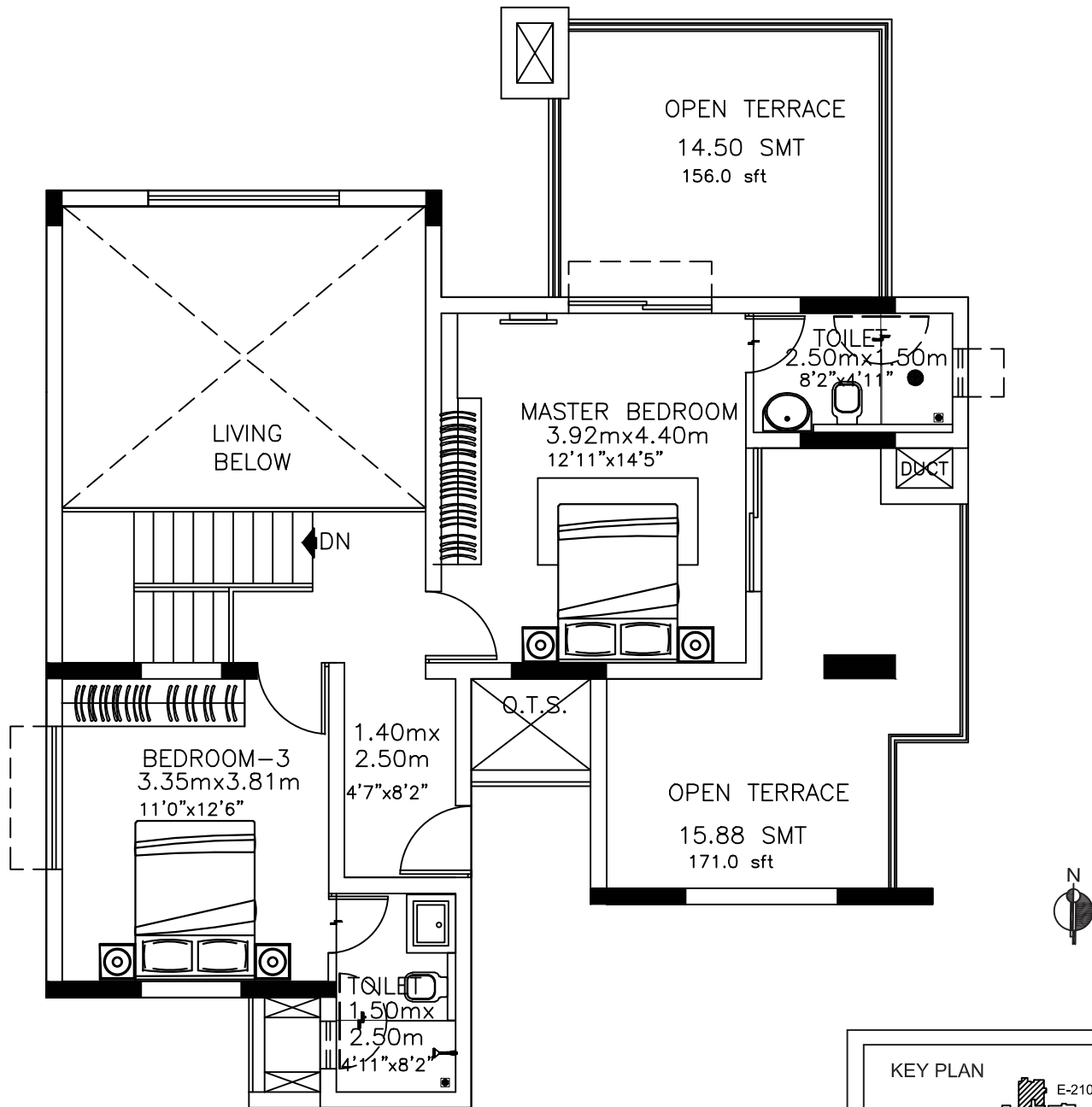

22ND FLOOR

E 2103 : 4 BED DUPLEX FLAT

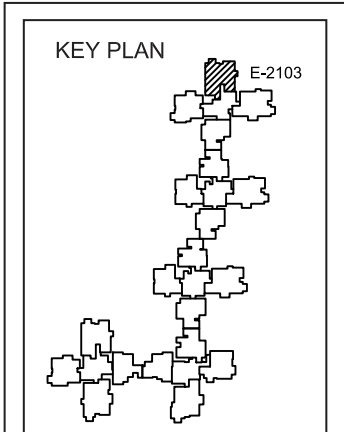

E-2103
4 BED DUPLEX FLAT
CARPET AREA -1,631 SFT

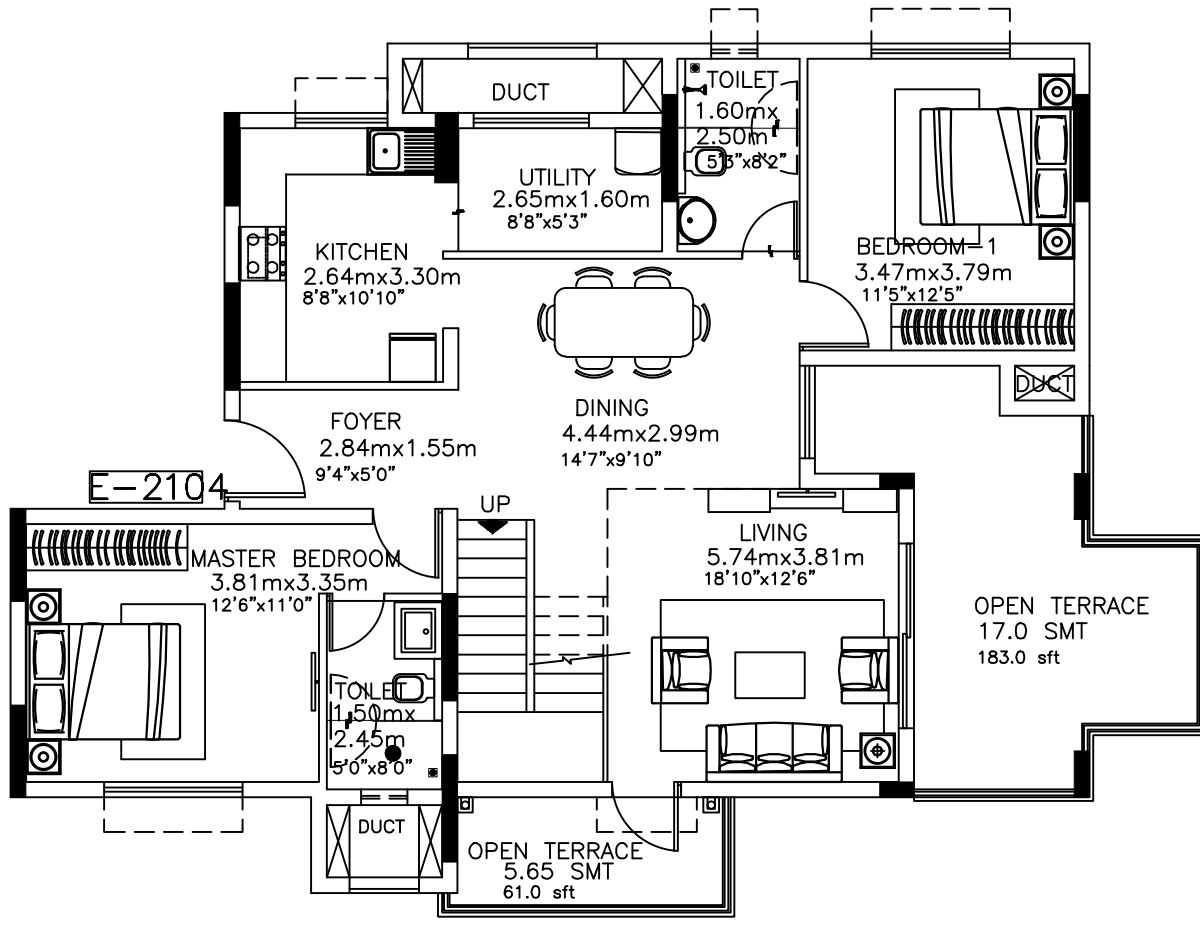

21ST FLOOR



E 2104 : 4 BED DUPLEX FLAT

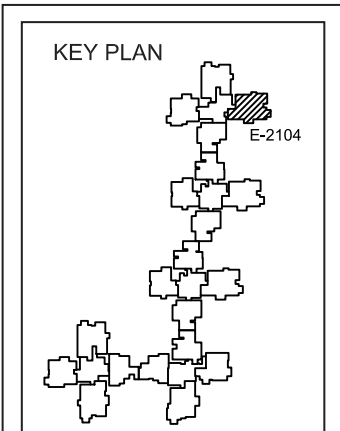

E-2104
4 BED DUPLEX FLAT
CARPET AREA -1,468 SFT

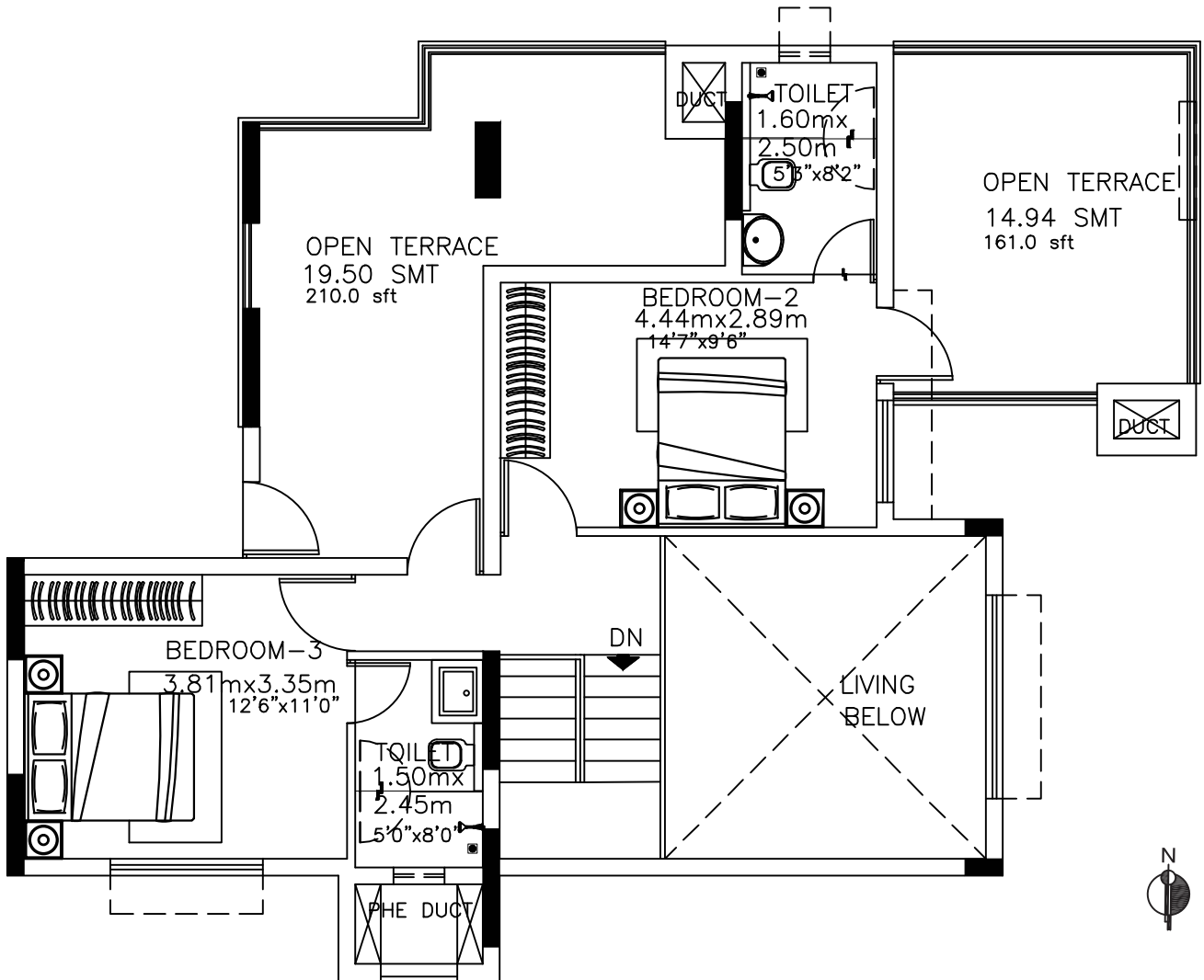

22ND FLOOR

E 2104 : 4 BED DUPLEX FLAT

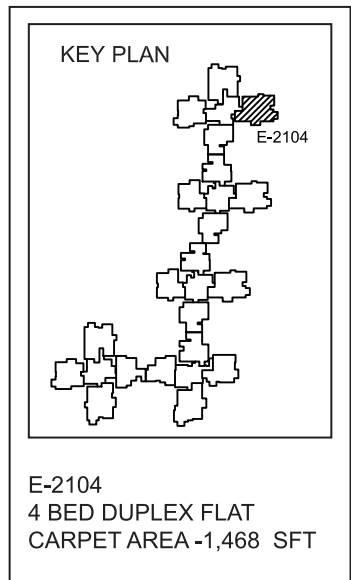

DISCOVER
HOW SOME
PLANS CAN
REDEFINE
YOUR FUTURE.
SPEAK TO US.



Kolte-Patil Developers Ltd
The Estate, No 121, 10th Floor ,
Dickenson road, Bangalore - 560042
ENQUIRE NOW: 1800 266 6654



Scan QR code
to view actual model flat



Project financed by TCHFL

I-TOWERS Exente : PRM/KA/RERA/1251/310/PR/171026/000862

Disclaimers:

While every reasonable care has been taken in preparing this Brochure, the developer and its agents shall not be held responsible or liable for any inaccuracy in its contents. All representations are believed to be correct and as envisaged by the developer. However, since the project is under evolution there is a possibility that there may be certain changes in the representations made in this Brochure. Every interested purchaser should take note of this express representation. Further, all art renderings, illustrations, photographs and pictures contained in this Brochure are an artist's impression only and the same should be not be construed to be the final image / view of the final project. Photographs do not necessarily represent build standard specifications. Intending purchasers are requested to note that the exact details related to the Project shall be enumerated in the Sale and Purchase Agreement that shall to be entered into between the Developer and the Interested Purchaser and shall supersede all statements or representations made prior to signing of such sale and purchase agreement and shall in no way to be modified by any statements or representations made by us or any of our representatives or the marketing agent. This Brochure content does not constitutes an offer and / or contract of any type between the Developer/Promoter/Owner and the recipient, all intending purchaser/s in this project shall be governed by the terms and conditions envisaged under The Real Estate (Regulation And Development) Act 2016.. The company/firm is not responsible for the consequences of any action taken by the viewer relying on such material/information provided in the Brochure.
Please contact our Sales Team at +91 80 4662 4444 (India) / rera.itowersexente@kotlepatil.com for the updated sales and marketing information and collaterals.